

EE Times

For the creators of technology

europa

MEMS shrink gas chromatography



Executive interview:
Atmel's Jörg Strughold

Special focus:
Medical Electronics



**FREE
SHIPPING**
ON ORDERS
OVER €65!



DIGIKEY.COM/EUROPE

2.5
MILLION
PRODUCTS
ONLINE

660,000+
ELECTRONIC
COMPONENTS
IN STOCK

600+
AUTHORIZED
SUPPLIER
PARTNERS

THE WORLD'S LARGEST SELECTION OF ELECTRONIC COMPONENTS AVAILABLE FOR IMMEDIATE SHIPMENT!®

WHICH SINGLE DISTRIBUTOR COMES TO MIND
AS BEING 'BEST OF CLASS' FOR BROADEST
OVERALL PRODUCT SELECTION?



Source: 2012 Design and Supplier Interface Study,
Hearst Business Media, Electronics Group







FIND CONTACT AND ORDERING
INFORMATION FOR YOUR REGION AT
DIGIKEY.COM/EUROPE

*A shipping charge of €18.00 (£12.00) will be billed on all orders of less than €65.00 (£50.00). All orders are shipped via UPS for delivery within 1-3 days (dependent on final destination). No handling fees. All prices are in euro and British pound sterling. If excessive weight or unique circumstances require deviation from this charge, customers will be contacted prior to shipping order. Digi-Key is an authorized distributor for all supplier partners. New product added daily. © 2013 Digi-Key Corporation, 701 Brooks Ave. South, Thief River Falls, MN 56701, USA

OPINION

- 4 Uncommon Market: European chip industry throws switches to regain global competitiveness
- 50 Last Word: Raising the standard

NEWS & TECHNOLOGY

- 6 Kontron launches High-Speed CompactPCI Initiative for 600Gbit/s interconnect 
- 6 Human body provides framework for secure, low-power communication channel
- 8 Four-year PLAT4M project to secure Europe's silicon photonics supply chain
- 8 CSEM's Photovoltaic Systems Center operational
- 10 Infineon readies next-generation power transistor production 
- 12 Wireless control drives Atmel in Europe
Atmel's recent acquisition of Osmo Devices with a WiFi Direct design center in Cambridge and some key microcontroller launches has seen the company focus heavily on wireless control in Europe says Jörg Strughold, Vice President of European Sales. 
- 13 R&D focus on automatic driving
Carmaker BMW and electronic supplier Continental announced plans to jointly create the technology required for highly automated driving.
- 14 Silicon nanocrystals bring light into the smallest dimensions
A joint research team of the Toronto University and the Karlsruhe Institute of Technology (KIT) has succeeded in creating nanoscale silicon-based LEDs (SiLEDs). 
- 14 CEA-Liten claims first ever printed ADC made on plastic foil
- 15 Free form screen takes any shape
- 16 Intel to make 14-nm FPGAs for Altera
- 16 Boron nitride nanotubes channel osmotic power

DESIGN & PRODUCTS

SPECIAL FOCUS: - POWER MANAGEMENT

- 17 Who's managing your power management?
- 18 Fan speed control through digital power management

- 21 The three essentials of RTL power optimization

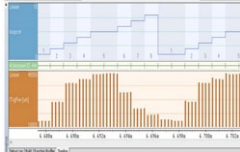
- 22 Power-aware debug emerges
There is increasing focus on the analysis and debugging of power in embedded designs and this is adding a new dimension for system developers. 

- MEDICAL ELECTRONICS

- 28 The challenges of designing medical devices
Designing a product for a medical application is probably one of the biggest challenges for a design engineer because of the confusing jungle of standards and guidelines. 
- 30 What to consider when selecting medical device interconnects
- 32 Using color sensors to diagnose skin diseases
Color related skin conditions or alterations can be determined accurately using optical instruments. 
- 34 Implementing real-time geolocation for medical personnel and patients
- 36 Patient-managed care and telehealth technologies drive medical design trends

- MEMS TECHNOLOGIES

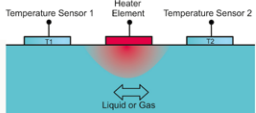
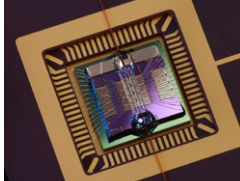
- 38 Designing closed-loop MEMS-based capacitive inertial sensors
- 40 MEMS accelerometers target healthcare applications
- 42 MEMS sensor signal conditioning for a thermal flow meter 
- 44 MEMS shrink gas chromatography
Analytical Pixels' compact portable gas chromatography device relies on the fine assembly of a functionalized nanoelectromechanical system sensor array, a silicon-based MEMS microfluidics gas column and MEMS silicon valves. 

READER OFFER

- 46 Atmel is giving away three ATmega256RFR2 evaluation kits, worth \$349 each, for EETimes Europe's readers to win. 

49 DISTRIBUTION CORNER

European chip industry throws switches to regain global competitiveness

By Christoph Hammerschmidt

FOR SOME TIME NOW, the European chip industry has had difficulties to define its future. Confronted with the choice of “More Moore” and “More than Moore”, the industry as a whole found no clear answer as to which strategy would be the most promising. An extremely capital-intensive transition to the 450mm wafer technology (More Moore) and an application-oriented design and manufacturing approach could be the new route. At the recent International Strategy Symposium (ISS), organized by industry association SEMI Europe, prominent representatives from European chipmakers, research institutions and equipment providers finally found a common denominator that satisfied all participants - the industry could and should unfold activities in both directions, the panel suggested.

This surprising and courageous message was the result of two factors: first, the industry rethought its strengths in Research and Development as well as its technology leadership in substantial parts of the equipment market, namely lithography. And, second, it certainly played a role that the European Commission over the past months developed a sense of understanding for the needs of this industry: in May 2012, the EC's commissioner for the Digital Agenda, Neelie Kroes, aired the idea of creating an “Airbus of Chips” - much like the creation of Airbus Industry in 1970 which laid the foundation to reinvigorate the European aerospace industry. The panel participants at the ISS represented heavy-weights of the European semiconductor industry such as Jean-Marc Chery, CTO of chipmaker STMicroelectronics, Luc Van den hove, CEO of Belgian research institute Imec and Rob Hartman, Director Strategic Technology Program of lithography equipment vendor ASML. The European Commission sent its Director Components and Systems Khalil Rouhana to the panel.

There has never been a doubt that in terms of technology and expertise the European chip industry is at the leading edge, but amidst heavy price pressure, the discussion of the past decade instead gyrated much about the question if there is a level playing field in the competition with its Asian and American counterparts. Such a level playing field could be within reach, should European policymakers such as Neelie Kroes prevail. “The good news is that EU nations are approaching the idea that industrial policy is a good idea”, said ASML's Rob Hartman. “Otherwise all the expertise will be depleted from here”. By the same token, IMEC top executive Luc Van den hove welcomed Kroes' idea of an Airbus of chips. “Such a thing holds

a lot of value - be it as a single company or as a framework of companies”, the science manager said. In order to bring such a joint effort to success, the European chip industry needs “to push the full value chain”, corroborated STMicroelectronics chief technologist Jean-Marie Chery. “We are ready to move”, he urged, “but we need to capitalize on our strengths and we have to move fast.” Confronted with so much enthusiasm, Khalil Rouhana as the representative of politics did not want to stay behind and held out the perspective of establishing a new Joint Technology Initiative (JTI) on electronic components and systems as part of the EU's Horizon 2020 framework programme, spiced with a triple-digit million euro amount to foster R&D - and perhaps even pilot production lines.

Beyond politics and funding, the congress also discussed technology perspectives for the semiconductor industry. In his presentation, Luc Van den hove reminded that Europe's semiconductor industry in specific market segments undoubtedly occupies leading positions. Examples are microprocessor IP vendor ARM who empowers 95 percent of the world's smartphones, lithography systems vendor ASML who currently tops the global list of the largest equipment vendors, or STMicroelectronics who produces half of the world's MEMS for mobile handsets. The European chip industry contributes to innovation in many areas including transistor architectures and materials - this understanding

united more or less all speakers at the congress.

Dutch tool vendor ASMI provided insights in how innovative materials and improved processes enable the industry to perpetuate Moore's Law. Like low-k materials and improved metals in the past were important to reduce crosstalk in chips and achieve faster interconnects, today's Thin Film Deposition (aka Atomic Layer Deposition or ALD) is an important technology trend which enables chip architects to further downscale transistor topologies, explained ASMI Chief Technology Officer Ivo Raaijmakers. “ALD is not only a process technology”, Raaijmakers said. “It is potentially a whole new technology platform for enabling new materials.” He also pointed out that materials development is not such a fast-moving topic as chip design: it takes six to ten years for a new material to move through the R&D value chain and enter mass production. The materials in questions by the way are not only the much-discussed SiC and GaN for future generation of power semiconductors, LEDs and microwave amplifiers, but in its majority less spectacular materials. Examples are specific groups of oxides, nitrides and metals.



EC technology expert Khalil Rouhana made clear that the European Commission understands the situation of the European semiconductor industry.

Your question: Why full bandwidth up to 1 mV/div?

Our answer: For high signal fidelity and measurement accuracy on fast, low-amplitude signals.

The R&S®RTO oscilloscopes offer high vertical input sensitivity of up to 1 mV/div. They always operate at high measurement accuracy because the full bandwidth of the oscilloscope can be used at even the lowest sensitivity levels. Furthermore, the R&S®RTO oscilloscopes do not use software-based zooming. They show the signal's real test points at all sensitivity levels.

See for yourself

www.scope-of-the-art.com/ad/faq-bw

Warranty program

available until June 2013:

Register your new scope and get a five year warranty instead of three!

www.scope-of-the-art.com/ad/warranty.



Kontron launches High-Speed CompactPCI Initiative for 600Gbit/s interconnect

By Nick Flaherty

KONTRON HAS LAUNCHED a 'High-Speed CompactPCI Initiative' to support two high speed CompactPCI standards running up to 600Gbit/s. CompactPCI Serial (CPCI-S.0) is aimed at 3U form factors with PCIe, GbE, USB and SATA over a backplane while CompactPCI Serial Mesh (based on PICMG 2.20) for 6U form factors with 10GbE over a backplane. This initiative gives the CompactPCI bus architecture a next generation product enhancement providing CompactPCI applications with the performance boost from today's 40 to 50Gbit/s rates and extending the investment security of CompactPCI technology for another decade.

The scope of applications using 3U CompactPCI Serial (CPCI-S.0) is extremely broad and varied. It ranges from multi-processor systems for the computation of complex imaging processes to high-performance video or radar data recording through flexible SATA/RAID architectures, and from high bandwidth wireless communication with parallel working radio modules WLAN, UMTS, LTE right up to powerful multi-monitor systems in control rooms.

Sample applications for the new modular CompactPCI Serial Mesh (based on PICMG 2.20) systems are in high availability

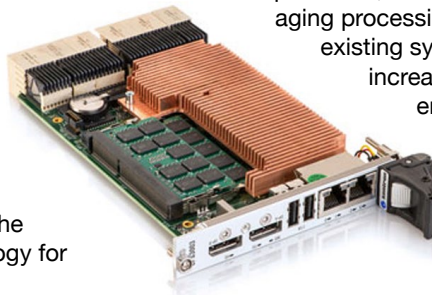

telecommunications and datacommunications applications for carriers and also with government and security companies. Applications include secure wireless systems, radar and sonar applications, and complex computational algorithms such as imaging processing. Now, even with smaller space requirements, existing system installations are provided with a significant increase in data throughput when new long-term generation systems are being developed which, in the future, could be scaled up to 40 GbE.

"CompactPCI Serial is a logical enhancement to the very successful and worldwide-accepted CompactPCI specifications. It enables a new generation of high-performance installations requiring massive bandwidth, and also provides a way to boost the performance of any existing CompactPCI deployments in a wide range of industries," explains Norbert Hauser, Executive Vice President Marketing at Kontron. "CompactPCI Serial allows data transmission at a rate of several gigabytes per second. By way of comparison, the highest possible data throughput via a parallel 32-bit/66 MHz PCI interface in CompactPCI is 0.264 GB/s. That means that with CompactPCI Serial, completely new system configurations become possible, and with 6U CompactPCI Serial Mesh, 10 Gigabit Ethernet means a huge performance increase too."

Human body provides framework for secure, low-power communication channel

By Paul Buckley

MICROCHIP TECHNOLOGY HAS unveiled a new low-power technology to provide designers with the world's first framework for using the human body as a secure communication channel. Compared to existing wireless methods, Microchip's BodyCom technology is claimed to draw lower power while further increasing security via bidirectional authentication. Because no RF antennas are required, BodyCom technology allows for simpler circuit-level designs and a lower bill of materials (BOM). All of this is enabled by the BodyCom Development V1.0 Framework, which is supplied through free software libraries that work on all of Microchip's more than 900 8, 16 and 32-bit PIC microcontrollers.

BodyCom technology is activated by capacitively coupling to the human body. The system then begins communicating bidirectionally between a centralized controller and one or more wireless units. There are a broad range of applications where secure wireless communication is essential, and there is no

more secure channel than the human body. This is especially true when you add bidirectional authentication that supports advanced encryption, such as KeeLoq technology and AES. For example, BodyCom technology helps prevent the 'Relay Attack' problem that is typical in automotive passive-keyless-entry security systems.

Most secure, short-range communication designs are battery powered and highly cost constrained. BodyCom technology significantly increases battery life by eliminating the need for a wireless transceiver or high-power inductive fields. It also simplifies development and lowers BOM costs by not only making antenna design unnecessary, but also by using a low-frequency framework with a common microcontroller and standard AFE frequencies (125 kHz and 8 MHz) - no external crystals are needed. And, because it complies with FCC Part 15-B for radiated emissions, BodyCom technology eliminates the cost and complexity of certification.

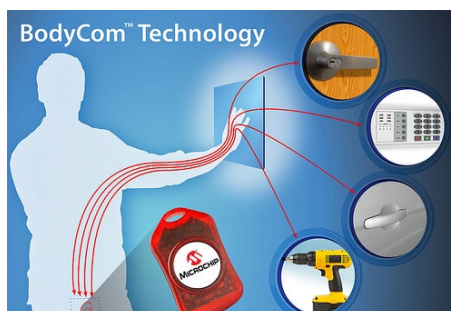

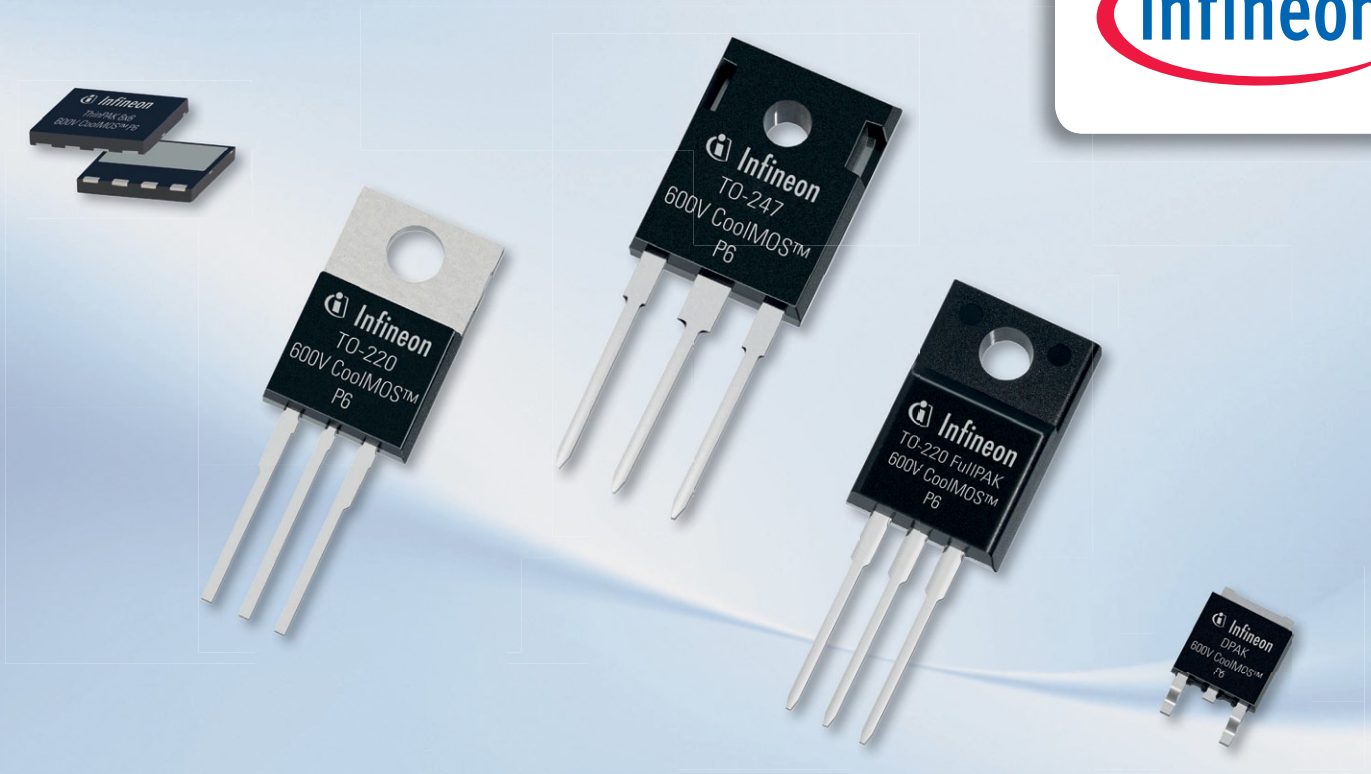

600V CoolMOS™ P6

Balancing High Performance with Ease of Use



With the new P6 series Infineon introduces a highly innovative CoolMOS™ product family, setting benchmarks in the price/performance Superjunction segment. It is designed to enable higher system efficiency whilst being easy to design in. The P6 generation closes the gap between technologies which focus on delivering ultimate performance and those concentrating more on ease of use.

Key features and benefits of 600V CoolMOS™ P6

- Higher efficiency especially in light load condition
- Good controllability and high robustness
- Suitable for hard- & soft-switching topologies
- Outstanding quality & reliability
- Optimized for applications such as Server, Telecom, PC Silverbox and Gaming Consoles

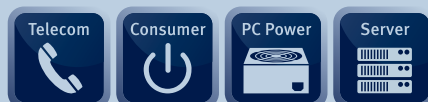

For further information please visit our website:
www.infineon.com/p6



Four-year PLAT4M project to secure Europe's silicon photonics supply chain

By Julien Happich

CEA-LETI HAS announced that it will coordinate the PLAT4M four-year project aimed at building a European-based supply chain in silicon photonics and speeding industrialization of the technology.

The PLAT4M (Photonic Libraries And Technology for Manufacturing) project will focus on bringing the existing silicon photonics research platform to a level that enables seamless transition to industry, suitable for different application fields and levels of production volume. PLAT4M, which is funded by a European Commission grant of 10.2 million euros, includes 15 leading European R&D institutes and CMOS companies, key industrial and research organizations in design and packaging, as well as end users in different application fields to build the complete supply chain.

"Silicon with its mature integration platform has brought electronic circuits to mass-market applications – our vision is that silicon photonics will follow this evolution," said Laurent Fulbert, Integrated Photonics Program Manager at CEA-Leti, coordinator of PLAT4M. "Upgrading existing platforms to become compatible with industrialization is now essential and this requires streamlining and stabilizing the design and process flows by taking into account design robustness, process variability and integration constraints. The PLAT4M partners bring a critical combination of expertise to the challenge of building a

complete supply chain for commercializing silicon photonics in Europe."

A surge in output of silicon photonics research in recent years has significantly boosted the potential for commercial exploitation of the technology. However, most of this R&D has been devoted to developing elementary building blocks, rather than fabricating complete photonic integrated circuits, which are needed to support large potential markets. The PLAT4M consortium will make technologies and tools mature by building a coherent design flow, demonstrating manufacturability of elementary devices and process integration and developing a packaging toolkit. The PLAT4M project will validate the complete supply chain through application-driven test vehicles representing various application fields. Based on technology platforms of Leti, imec and STMicroelectronics, and supported by a unified design environment, the project will prepare the supply chain for silicon photonics technology, from chip-level technology to packaged circuits, making integration technologies accessible to a broad circle of users in a fabless model. It will contribute to the development of a design environment that facilitates photonics/electronics convergence. One of the goals of the project is also to retain the key added value in components in Europe through optoelectronic integration, with little added value in offshore assembly.

CSEM's Photovoltaic Systems Center begins operations

By Paul Buckley

THE NEW PHOTOVOLTAIC SYSTEMS CENTER in Neuchâtel has become operational as a new division of CSEM. The center is dedicated to applied research and technology transfer in the domain of solar energy. The center has received CHF19 million of funding from the Swiss government for the period 2013-2016. Back in 2010, before even the Fukushima disaster and Switzerland's decision to abandon nuclear energy, the Swiss Center for Electronics and Microtechnology (CSEM) and the management of the Federal Polytechnic School of Lausanne (EPFL) submitted a proposal to the Swiss government for the creation of a center devoted to photovoltaic energy, to be located in Neuchâtel.

Three years later, the center is up and running, operational as of January 1, 2013. Financed by CHF 19M of training, research & innovation grants from the Swiss government for the period 2013-2016, the objectives of the new Photovoltaic Systems Center (PV-center) will be to speed up the industrialization process, develop the new generations of photovoltaic cells and modules, and support the transition to a national energy system in which solar power will play an essential role.

In view of the pressure on the solar sector worldwide (mass production, considerable investment by certain governments in research and technology transfer) and despite a good starting position in this sector, it is essential that Switzerland establish platforms that are able to support R&D and technology transfer activities. The country needs a professional and sustainable structure that can respond to the need for rapid industrialization of research results (transfer to industry) and provide effective support to all actors involved in the development of renewable energies.

Initially, the PV-center will rely on the scientific expertise of the PV-lab and the technical know-how of several engineers with experience of the industry. The PV-lab is the photovoltaic laboratory of EPFL's Institute of Microtechnology in Neuchâtel. The PV-center will be located in the same building as CSEM's microsystems technology operations, close to EPFL's new microtechnology building, Microcity, where the academic activities of the PV lab will take place. The geographical proximity will help speed up the transition from R&D to the market for current and future generations of PV systems.



MAXIMIZE VIDEO. MINIMIZE COST AND FOOTPRINT.

Lattice FPGA solutions deliver exceptional performance at up to half the cost and power of the competition. With advanced DSP, SERDES, sub-LVDS I/O and high-speed DDR3 support in extremely small footprints, they're the perfect choice for the tightest of space-constrained imaging applications. So keep innovating. We're ready.



Scan this to learn more
about our low cost,
low power FPGA solutions.

latticesemi.com/maxvideo



Infineon readies next-generation power transistor production

By Christoph Hammerschmidt

As a result of a three-year research project, Infineon announced it started volume production of power semiconductors on 300mm wafers as opposed to the 200mm wafers typically used throughout the industry for the production of power devices. What's more, the company produces these devices on so-called thin wafers - silicon wafers with a thickness of just 200 micron and probably less in the future. But what do these figures mean for Infineon's customers and the markets?

Thinner wafers translate directly into higher energy efficiency in many applications. In some transistor architectures such as the ones Infineon uses for its CoolMOS product family the electric current is directed vertically through the silicon between the Source and Drain electrodes - as opposed to other architectures, for instance in logic circuits, where the current runs horizontally through the semiconductor structures. In vertical structures, a thin wafer translates into a low resistance when the transistor is switched to "on" (RDSon) - and this means lower losses for applications such as LED drivers, server power supplies, photovoltaic inverters or electric drives in industry and mobility. The thinner the wafer, the lower is the resulting RDSon. Infineon claims it can reduce the wafer thickness down to 100 microns with its next goal at 40 microns.

While 300mm wafers is well established in the production of logic circuits, in the realm of power electronics 200mm is the prevailing diameter. The move from 200mm to 300mm gives the manufacturer a productivity boost: at a given device geometry, a 300mm wafer accommodates about 2,3 times more devices than on a 200mm wafer. Infineon claims to be so far the only semiconductor manufacturer using this technology. This competitive edge should secure high margins for Infineon - or more competitive prices for the customers, or a combination of the two.

The ability to master these processes and technology however does not mean that the productivity gain will be reflected 1:1 in lower prices or higher margins. The development of the manufacturing processes, in particular for reducing wafer thickness and for handling these thin and thus floppy wafers, swallowed significant amounts of money. "Handling

these wafers is anything but trivial," said Kurt Aigner who oversaw the Power 300 R&D project resulting in these technologies.

Particular care is needed to insert and remove the thin silicon objects - they actually resemble more a foil than a wafer - to the processing tools and during transport. During critical production steps, the wafer bend must not exceed one micron. Another challenge lies in the high-temperature processes with temperatures up to 1100°C used in the production of power transistors. It is very important that heating and cooling in these cycles is

applied to the entire wafer very evenly to avoid thermal tensions inside the monocrystalline silicon wafers. If not mastered correctly, this process step could result in a complete failure of the wafer. These difficulties perhaps are one of the reasons why Infineon prefers not to talk about the yield of its thin wafer production. And since the tools and machinery required are more expensive than for a standard 200mm production line, the production costs decline just by 20 to 30 percent though the theoretical productivity gain is more than 120 percent.

Infineon developed the 300mm thin wafer technology in its plant in Villach, Austria, the main pillar of Infineon's power semiconductor production. The company now plans to implement the same process technology at the fab it

bought back in 2011 from the insolvent assets of Qimonda in Dresden. This fab shares a campus with Infineon's active fab for logic products. The power devices production on 300mm thin wafers in Dresden will start in March. However, against the current market situation, it should not be expected that the facility will be utilized to capacity anytime soon. In Infineon's power device production, the current utilization is only 75 to 80 percent and the added capacity will certainly not help to increase this utilization. At least not immediately, but Infineon plans to be ready when the economic situation improves and the demand rises. Infineon CEO Reinhard Ploss expects the upswing to start in the second half of the year. For the company, it is an important aspect to secure the sales resulting from rising demand once it will be manifest. "Our signal is: we are ready to supply", Ploss said.

The announcement followed the first go-ahead from major customers. Infineon declined to name them, but Ploss said that this market is particularly active in Asia. In terms of applications, the market for CoolMOS products is extremely diversified, he added.

And what will be the direction for future technologies and products? Ploss declined to be overly specific, but he hinted that Infineon's expertise in logic ICs and power devices could be combined to design highly integrated intelligent power devices - in his speech, Ploss coined the term "Power SoCs".

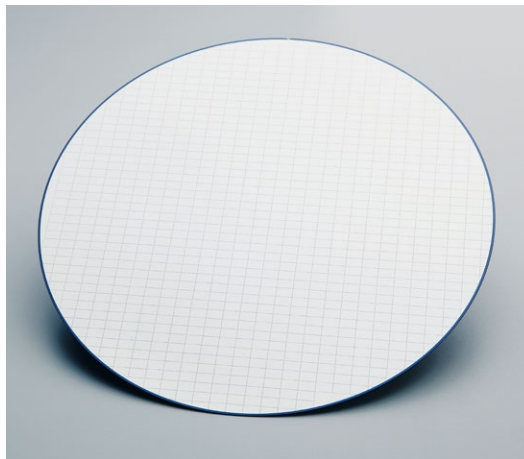

Thinner than a sheet of paper: the wafers for Infineon's power transistors are difficult to handle but promise superior product properties.



The former Qimonda fab (far left) on Infineon's Dresden campus will be added to the company's power semiconductor manufacturing capacity.

A REAL BROADSIDE!

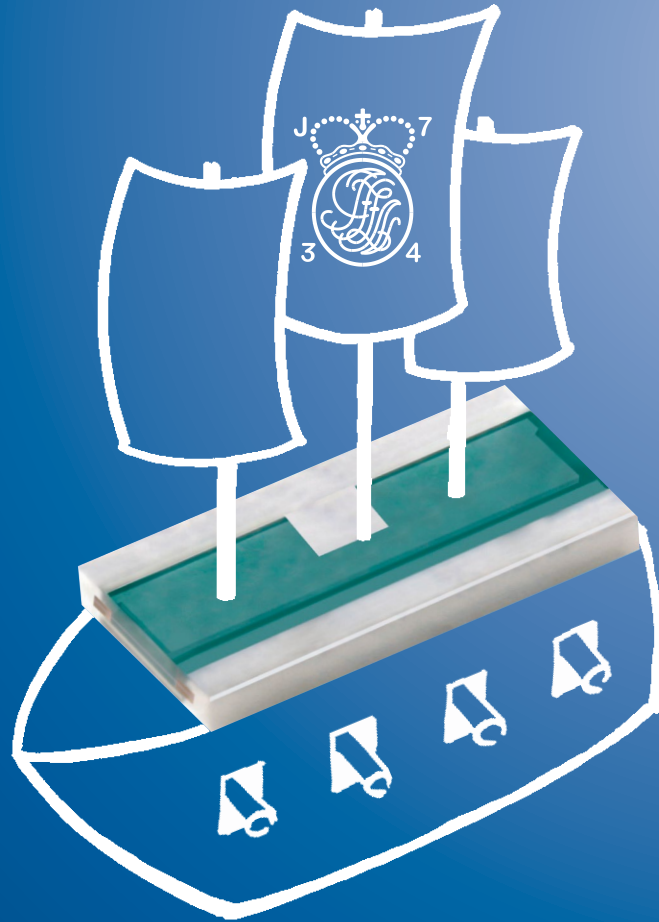

LOW OHMIC PRECISION AND POWER RESISTORS



TOP PERFORMANCE ON SMALL SURFACE AREAS WITH LOW-OHMIC PRECISION RESISTORS

By reversal of the length to width ratio, our VLx series resistors have larger soldering and contact pads, giving them:

- _ better heat dissipation, $R_{thi} < 20 \text{ K/W}$
- _ higher power rating: 2 W for size 1020, 1 W for size 0612
- _ significant increase in mechanical stability



ISABELLENHÜTTE

Innovation by Tradition

Isabellenhütte Heusler GmbH & Co. KG
Eibacher Weg 3-5 · 35683 Dillenburg · Phone +49 (0) 2771 934-0 · Fax +49 (0) 2771 23030
sales.components@isabellenhuetten.de · www.isabellenhuetten.de

Wireless control drives Atmel in Europe

By Nick Flaherty

ATMEL'S RECENT ACQUISITION of Osmo Devices with a WiFi Direct design center in Cambridge and some key microcontroller launches has seen the company focus heavily on wireless control in Europe says Jörg Strughold, Vice President of European Sales.

What impact has the recession had on Atmel's business in Europe?

Our microcontroller revenue globally has grown in four consecutive quarters globally which is very positive in a challenging environment and Europe had its place to play in that, but it is fair to say there was an impact from the overall economic situation in Europe. At the same time our key revenue drivers in Europe are industrial, automotive and consumer and looking into 2013 we see some nice growth opportunities in those segments and that is what's driving the momentum in the market. If you look at all the recent activity we have been very much looking forward into 2013 with demand creation through our 32-bit products where we have launched over 95 32-bit derivatives.

Atmel has strong 32-bit and 8-bit microcontrollers. Are you seeing a shift from 8-bit?

We have a very strong 8-bit offering with a nicely orchestrated set of peripherals, particularly strong in analog, low power, high code efficiency and we have good scalability. Together with the customer we select the right controller for the right application, and we believe we have a very good answer to the needs, not driven by a specific core but by a specific set of peripherals, power budget and connectivity and that's how we develop our roadmap to support the customer. 2012 was a difficult year for the semiconductor industry but we have been able to grow our contribution through microcontrollers.

Do you see a recovery in Europe, if so in which sectors and why? Where are the growth opportunities in sector and geography?

The industrial segment is probably the strongest with more microcontrollers for more connectivity, white goods, lighting, metering will be a strong growth driver for the future - this will pick up with many deployments across Europe. Lighting whether LED or smart lighting will also drive growth and we will for sure see in Europe with the diversified customer base much equipment that will be connected to the Internet of Things. With the WiFi acquisition we have expanded our portfolio in this area especially with the connectivity for the Internet of Things

What is Atmel's current fab capacity in Europe for which products, and what are the plans going forwards - particularly for security products, embedded flash and wireless?

We do have foundry capacity in Europe but in general our manufacturing footprint we have one Atmel fab in Colorado Springs and as part of the fab lite model we have divested our fabs and using foundry capacity around the globe, some of it in Europe and following a dual sourced technology strategy.

We work with Telefunken in Heilbronn for automotive products. We left the smart-card business in 2010 and now source our secure microcontroller products from multiple foundries

What is the Atmel embedded flash strategy and roadmap?

We have just introduced the highest embedded flash device at the lowest power with a Cortex M4 core. The flash requirements are driven by the different applications and when you go back to the European drivers you have a very diverse set of applications from toothbrushes and coffee makers. You are talking about very small flash sizes there so we are providing flash densities to serve the application needs of our customers

How is the Xsense touch screen sensor technology progressing - what opportunities are opening up for European companies as a result?

You can certainly say it has been well adopted and we just started shipping it to Asus in Taiwan. Smartphone and tablet industry in Europe is a definite opportunity but we also see opportunities for any touch screens, from toy manufacturers, smart watches and small appliances to large white goods and see some traction into the industrial market for larger screens. The flexibility can provide unlimited opportunities for the development of new form factors and the recent partnership with Corning for gorilla glass with curved surfaces makes the product very attractive from industrial design perspective with larger, sleeker screens for touch enabled products.

How important is wireless technology to Europe from Atmel's perspective?

How important is wireless technology to Europe from Atmel's perspective?

Wireless is very important for Europe. Connectivity always plays a very important role. We have also invested in the power-line communications but wireless is very important, Zigbee in industrial and other applications such as remote control. Another wireless element in Europe is automotive with remote keyless entry which is very significant. The acquisition of Osmo Device adds another element and they have a strong foothold in the UK with the design centre in Cambridge and we have a strong



Jörg Strughold, Vice President of European Sales, Atmel

Strughold joined Atmel from Qimonda, the former memory division of Infineon Technologies, where he was global head of sales and marketing as well as regional president for the European region. Prior to Qimonda, he led the European sales organization at Infineon and has also served as a marketing manager at Siemens Semiconductor's Microcontroller Business Unit.

history of European acquisition and that continues with Osmo. These new products will complement our wireless portfolio with the innovative WiFi Direct technology with remote control being a very strong application there and everything on the accessory side from keyboards to wireless speakers where you have many companies across Europe that are active. There's also the Internet of Things where WiFi Direct is another interesting option.

What are the key opportunities for Atmel in Europe?

Lighting, metering, home automation, where wireless is a key capability

Are there plans to boost R&D in the region?

We have a very, very strong R&D footprint, whether micro-controller R&D in France and Norway, automotive and Zigbee in Germany, and strong product competency. We do have a strong European footprint and do take advantage of the very strong European engineering base. We are acting as a global company and equipping ourselves with R&D talent around the globe and Europe has a very strong footprint.

R&D focus on automatic driving

By Christoph Hammerschmidt

CARMAKER BMW AND ELECTRONIC supplier Continental announced plans to jointly create the technology required for highly automated driving. The R&D project is designed to run until the year 2014 and includes automatic driving even on high-speed motorways.

In January, the two companies signed an agreement to jointly develop an "electronic co-pilot" system capable of supporting highly automated driving. The main goal of the research partnership is to have highly automated driving functions ready for implementation until 2020 and thereafter. At the social, political, economic and scientific level,

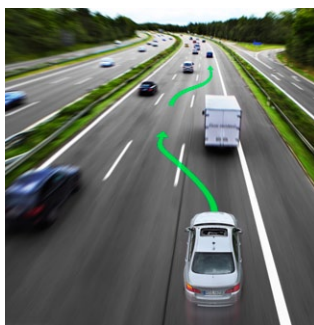

a vision has now emerged for road safety – in the form of "Vision Zero (Accident-Free Mobility)" and "Safety for All". The research project on highly automated driving will aim to implement this. In addition to the safety aspect, the researchers also see opportunities for improved convenience and efficiency. "With our vision of highly automated driving, we are developing the technologies and methodologies for a range of cutting-edge driver assistance systems. Partially automated driving functions of the near future, like the traffic jam assistant, will mark an important step on the road to highly automated driving," says Christoph Grote, Head of BMW Group Research and Technology. Over the two-year timeline until the end of 2014, a number of prototypes capable of highly automated operation on motorways will be developed. They will then be handed over to a selected group of trained test participants for pilot-testing of their near-production highly automated driving functions. The tests, which will take place on motorways throughout Europe, will take into account typical challenges such as motorway intersections, toll stations, roadworks and national borders.



GO mouser.com
The Newest Products for Your Newest Designs®

The Next Big Thing Is Here.

NEWEST PRODUCTS



The NEWLY redesigned Product Knowledge Center.

More Product Knowledge
More New Products
More Technologies



Authorised distributor of semiconductors and electronic components for design engineers.

Silicon nanocrystals bring light into the smallest dimensions

By Christoph Hammerschmidt

A **JOINT RESEARCH** team of the Toronto University and the Karlsruhe Institute of Technology (KIT) has succeeded in creating nanoscale silicon-based LEDs (SiLEDs). According to the researchers, these nanocrystals, consisting of only a few hundreds to some thousand atoms, offer significant potential as highly efficient light emitters. Commercially available LEDs are made of direct band gap materials, mainly combinations of gallium. Silicon hitherto was considered unfit for use in LEDs since it only can generate light in the red and near-infrared spectrum. The researchers from Karlsruhe and Toronto have changed this perspective. The extremely tiny silicon nanocrystals they created (one to three nanometers in size) emit light. The light color depends on the size of the crystals: the bigger the crystal the longer the wavelength of the light emitted.

The research team around Uli Lemmer and professor Annie K. Powell (Karlsruhe) and professor Geoffrey A. Ozin (Toronto) also developed a process to separate the nanocrystals by size. This enables them to build tiny LEDs with specific colors and combine several LEDs to multi-color arrays. "The innovation is the controlled production of silicon LEDs emitting various colors", said doctoral candidate Florian Maier-Flaig from the Karlsruhe School of Optics and Photonics who contributed to the research activities. The architecture of such SiLEDs resemble OLEDs in that stacks of these solid state devices are contacted and powered in parallel. They so far however are unable to generate white light. White light theoretically could be generated by mixing different colors, but so far no blue-light emitter has been developed.

The SiLEDs feature a surprising long-term stability which has not been achieved before, Maier-Flaig said. This property is a consequence of the scientists' ability to separate the objects by size – the relatively large objects no longer can cause electric shortcuts. In addition, the SiLEDs they create feature a very high homogeneity of the light-emitting surfaces.

The researcher were also pleased by their SiLED's relatively high efficiency of about 1 percent. If one compares this value with conventional LEDs this does not seem to be very impressive, but there is no physical limit to the efficiency, explained Maier-Flaig. Another advantage of the silicon nanocrystals is that they don't contain toxic heavy metals. Unlike cadmium



SiLEDs offer huge potential for lighting and active screen applications. The contacts are made of organic materials.

selenide, cadmium sulphide and lead sulphide used by other research groups, silicon nanocrystals do not contain any toxicity. The SiLEDs are still far from being commercialized. The Karlsruhe researchers see potential technical applications in area lighting - for example screen backlighting. In order to bring this technology closer to a commercial use the research teams announced to continue their activities with partners.

CEA-Liten claims first ever printed ADC made on plastic foil

By Julien Happich

CEA-LITEN PRINTED electronics technology has allowed to process the first printed analog to digital converter (ADC) ever made on plastic foil. Developed in collaboration with Eindhoven University of Technology, ST Microelectronics and University of Catania, the organic transistors manufactured at CEA-Liten are processed using printing techniques on plastic sheet. The ADC circuit block could be used to convert to digital bits the analogue values read from a sensor (which could also be printed on packages of perishable goods to monitor their freshness). The ADC circuit was made with screen-printing techniques, it

includes more than 100 n and p type transistors and a resistive layer on a transparent plastic sheet. The ADC circuit offers a resolution of 4-bits, and has a speed of 2Hz. It was designed in the framework of the EU project COSMIC (Complementary Organic Semiconductors and Metal Integrated Circuits). The carrier mobility of the printed transistors is higher than the one observed in amorphous silicon, which is widely used in the display industry (CEA technology p type $\mu_p = 1.8 \text{ cm}^2/\text{V.s}$ – n type $\mu_n = 0.5 \text{ cm}^2/\text{V.s}$).

Free form screen takes any shape

By Nick Flaherty

MITSUBISHI ELECTRIC HAS developed a prototype display system with an optical engine that can project images on curved, oval or triangular screens to suit a wide range of car interiors. The system's three LED free-form screen responds flexibly to the increasing use of curves and other design features in car interiors. It uses display technologies from rear-projection TVs as well as car electronics that withstand severe operating conditions, ensuring high quality and reliability, and the company has 11 Japanese patents and three international patents pending.

The 'curve-variable' optical system projects images on screens of various shapes to minimize blur in screen areas with deep curves. The prototype system's single optical engine adapts to a wide range of surfaces, unlike conventional displays that require a designated optical engine designed for a screen's specific curves or shape. Natural, distortion-free images are projected on curved, oval or triangular surfaces through a screen distortion adjustment process that predicts the distortion of images caused by complex curves, and adjusts visual signal input.



To ensure steady performance and extended product life, Mitsubishi has also developed a hybrid cooler that combines radiation and natural and forced-air cooling. In addition, the overall structure minimizes distortion of the optical engine and chassis due to vibration or shock while driving, ensuring that images remain crisp and clear. The display also incorporates a plastic screen that absorbs light to maintain excellent visibility in bright environments.

The display system (above) incorporates red, green and blue LEDs for its light source to achieve a color gamut 1.5-times wider than conventional displays that use white LED backlights. The three different LEDs produce brighter colors and increased visibility. In addition, a light sensor separately controls light emissions from the different LEDs, each having its own temperature characteristics, and maintains color balance to stabilize color reproduction in a wide range of temperatures.

THE ORIGINAL MEDICAL PUSH-PULL CONNECTOR



Redel 1P Series

- Self-latching plastic connectors
- Sterilizable
- Solder, crimp and print contacts
- Fluidic connectors
- From 2 to 14 contacts

Redel 2P Series

- Self-latching plastic connectors
- Sterilizable
- Solder, crimp and print contacts
- From 16 to 32 contacts

Redel 3P Series

- Sterilizable
- Fibre optic, coaxial or high voltage contacts
- Hybrid connectors
- From 6 to 18 contacts



REDEL IS A LEMO GROUP COMPANY - Switzerland
Phone: (+41 21) 695 16 00
info@lemo.com



Contact your local partner on www.lemo.com

Intel to make 14-nm FPGAs for Altera

By Rick Merritt

INTEL CORP. WILL build FPGAs for Altera Corp. using its 14-nm FinFET process technology in a deal that turns up the heat on TSMC in foundry and Xilinx in high-end FPGAs. The deal marks the largest of a string of publicly disclosed foundry deals for Intel to date and its first at 14 nm but is not expected to result in products until 2014.

Altera (San Jose, Calif.) declined to disclose details of the deal, including what products it will make when. However, Altera CEO John Daane did say he believes Intel is two to four years ahead of other foundries with its 14-nm FinFET process, which Altera will use initially to give its highest-end FPGAs advantages in density, performance and power. High-end parts make up about half the FPGA market, with Altera claiming a lead with 40- and 28-nm parts that it aims to extend with the new Intel process. Besides winning more business away from rival Xilinx, the 14-nm parts could help Altera grab more sockets away from ASICs and application-specific standard devices, Daane said.

Intel promised Altera access to the 14-nm process for 12 years to satisfy long-term availability requirements of defence and other customers, Daane said. The multi-year deal allows Altera to use other existing and future nodes, but the FPGA maker initially will focus on high-end parts at 14 nm, he said.

Using multi-die chip stacks, Altera currently ships an FPGA that packs 1.2 million logic elements, lagging a similar chip from Xilinx with 2 million logic elements. However, such parts have relatively high costs and power and take a performance hit due to additional on-chip communications. They are used “for prototyping predominantly—it’s a niche,” Daane said.

Altera surveyed foundries for a year before striking the deal with Intel. It will continue to make chips at TSMC and conduct ongoing evaluations of other processes as they develop.

Daane cited reports that other foundries are grafting a first-generation of FinFETs on to existing 20-nm design rules to create what they are calling a 14-nm node. “Intel’s 14-nm is a second generation FinFET process, while others are just starting to imple-

ment their first,” he said. The deal marks “a significant departure for Altera,” said Deutsche Bank analyst Ross Seymore, who doesn’t expect Altera to see revenue from it until 2015. It is also “a validation of Intel’s manufacturing leadership” that “should help Intel make gains in foundry services,” he added. “It is not Intel’s objective to become a general foundry service provider,” said Len Jelinek, a chief analyst at IHS iSuppli. Rather it aims “to select a few high volume [foundry] clients [that] provide Intel with an additional revenue stream to help defer the cost of its advanced manufacturing capability,” he said.

Intel says 14-nm node ready this year

To date, Intel has announced it is making chips in its 22-nm FinFET process for two FPGA startups, Achronix and Tabula, and network processor maker Netronome. Achronix officially started sampling its FPGAs based on Intel’s 22-nm technology last week, claiming it is two years ahead of competitors using TSMC.

Unconfirmed reports have said Intel could be making 22-nm ASICs for Cisco. Others said the PC chip giant may be working on a deal to make mobile processors for Apple, which is trying to reduce its foundry dependence on archrival Samsung.

Daane expressed confidence Intel will be able to meet Altera’s volume requirements. “Clearly this is a step up for us,” said an Intel spokesman. “We were proceeding slowly and cautiously [into the foundry business] and now we are increasing the pace,” he said.

Intel will have its 14-nm process in production later this year, the spokesman added. Globalfoundries announced last fall it plans to accelerate its road map, making a 14-nm process available some time in 2014. The Altera deal “puts Intel out there as a contender in the foundry market,” said Joanne Itow, manufacturing analyst at Semico Research Corp. Itow noted that TSMC founder Morris Chang listed Intel as a competitor in a recent conference call. Altera will get at least a one or two year advantage using Intel’s 14-nm process, Itow said, but she doubted the FPGA maker will be able to ship the parts until sometime in 2014.

“Intel’s 14-nm is a second generation FinFET process, while others are just starting to implement their first” says Altera’s CEO John Daane.

Boron nitride nanotubes channel osmotic power

By Paul Buckley

THE INSTITUT LUMIÈRE MATIÈRE in Lyon (CNRS / Université Claude Bernard Lyon), in collaboration with the Institut Néel (CNRS), has discovered how to use boron nitride nanotubes to harness energy from the salinity difference between fresh water and salt water. The osmotic flow through boron nitride nanotubes generates electric currents that have 1,000 times the efficiency of any previous system. To achieve the result, the researchers developed an experimental device that enabled them, for the first time, to study osmotic fluid transport through a single nanotube. The experimental device consisted of an impermeable and electri-

cally insulating membrane pierced by a single hole through which the researchers, using the tip of a scanning tunneling microscope, inserted a boron nitride nanotube with an external diameter of a few dozen nanometers.

Two electrodes immersed in the fluid on either side of the nanotube enabled them to measure the electric current passing through the membrane. A massive electric current was generated through the nanotube, induced by the strong negative surface charge characteristic of boron nitride nanotubes, which attracts the cations contained in the salt water.

Who's managing your power management?

By Bob Frosthalm

TODAY'S COMPLEX SYSTEMS employ a wide variety of semiconductor technologies. From the deepest sub nanometer processors to the Analog I/O, it's easy to see the need for power management devices for 1.0, 1.2, 1.5, 1.8, 2.2, 2.5, 2.8, 3.0, 3.3V and more, all in the same box.

Dozens of companies offer thousands of chips to address these needs. Data sheets, PDKs and application notes make implementation easier than ever. If your volume is high enough, chip company application engineers are more than willing to do the design work for you. Sit back, watch You Tube, follow friends on Facebook and wait for the circuit to arrive by email. It's not quite that simple, but let's be honest, there are a lot of free resources out there to assist.

A few dozen years ago, engineers fresh out of school were assigned to the power supply team; the most boring and least challenging aspect of the system and the one most forgiving of inexperience. Could it come to that again?

Not likely. But you really should ask yourself, who is really managing your power management. Is it you or your suppliers? Who really understands your power management needs and more importantly, the solution you've implemented? Is your 7Amp 1.2V solution overkill for your 2.9Amp requirement? Could a lower cost LDO be used instead of that switcher?

"Gee, thanks Mr. Semiconductor Company Applications Engineer for designing most of my system with all your high margin chips. It sure plays nice in my application."

Power Management is more than developing solutions that run cool and conserve power. It's also about managing cost. With today's plethora of fifteen and twenty cent chips, it's easy to assume your design is financially viable. But is it?

Financial management is inextricably intertwined with power management. Often power management solutions transcend multiple product generations. It's the most logical place to drive cost out of a system for greater long term savings. Yet, for some reason, it's also the most overlooked.

Figure 1 represents the power board for a typical consumer application. Depending on total volume, the bill of materials may range from \$1.00 to \$1.50 at the low end, to perhaps as high as \$2.00.

However, integrating these seven chips into what is called an iASIC, or integrated ASIC, would yield a much lower cost single chip solution while retaining all the desired power saving functionality of the original designs. An iASIC as shown in figure 2 (a chip integrating existing functions without the need to create new IP) is easy to accomplish and has a short development

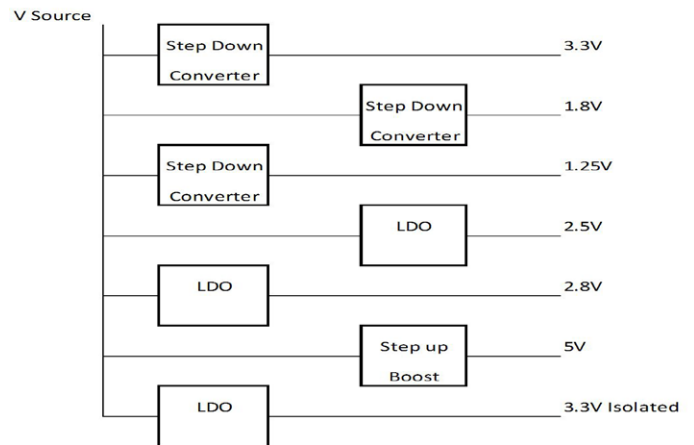

Fig. 1: the power board for a typical consumer application, whose bill of materials may range from \$1.00 to \$1.50 at the low end, to perhaps as high as \$2.00.

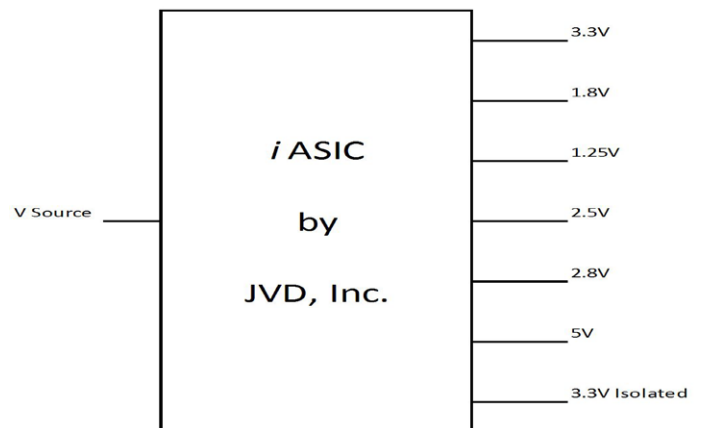

Fig. 2: an iASIC is easy to accomplish and has a short development time.

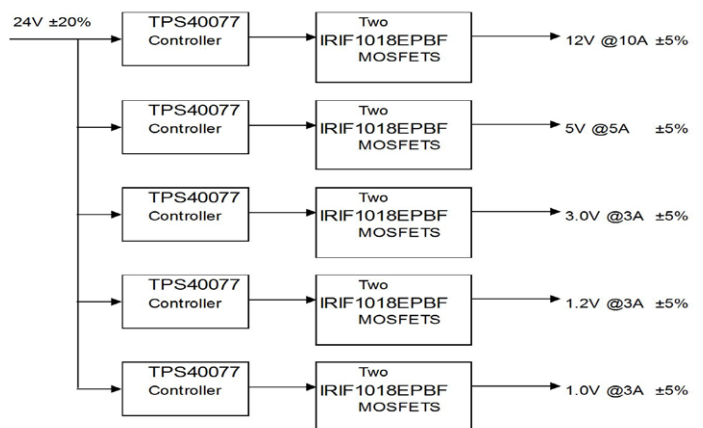

Fig. 3: an original industrial power supply design using five controllers and ten Power MOSFETs for which an iASIC would reduce BOM.

Bob Frosthalm is Director of Sales and Marketing at Analog ASIC company, JVD Inc - www.jvdinc.com – he can be reached at bob.frosthalm@jvdinc.com

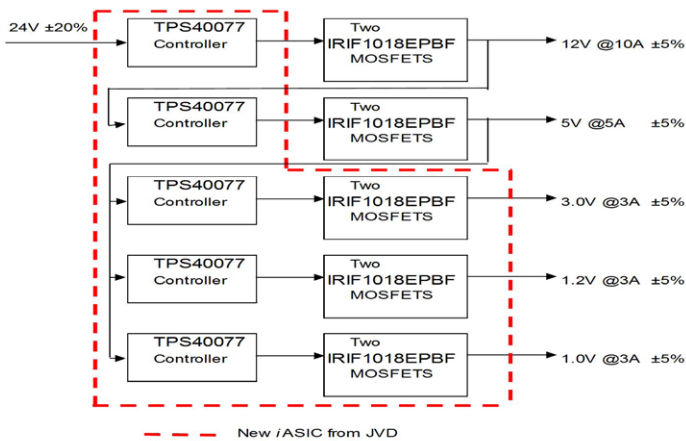

Fig. 4: Part count can be reduced by selectively choosing to integrate devices into the iASIC design (outlined in red).

time. The cost of the iASIC for the above set of requirements would be in the neighborhood of \$0.60 each. Another example can be described using an industrial power supply application. The original design uses five controllers and ten Power MOSFETs as shown in figure 3. The BOM cost is high, even in high volume. By selectively choosing to integrate six MOSFETs into the iASIC design along with the five controllers (see area outlined in red in figure 4), the part count can be reduced from 15 to 5 and the cost of the iASIC would be approximately \$1.50.

Power management is as much about power as it is about finance. The maniacal focus on conservation of energy and

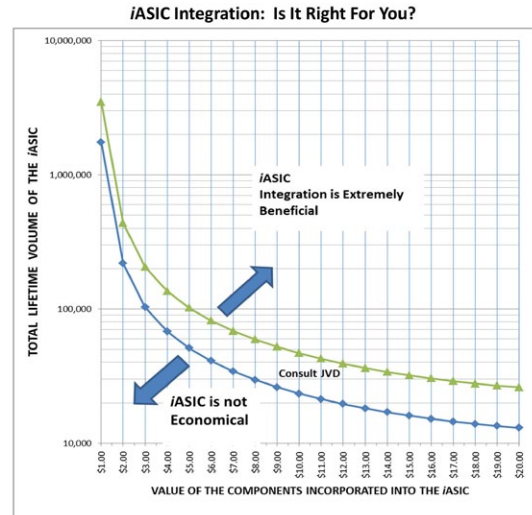

Fig. 5: the financial economic benefits of integration using an iASIC.

power needs to be coordinated with the conservation of cash. Figure 5 clearly shows the financial economic benefits of integration using an iASIC. These numbers are typical and include amortization of all NRE and tooling costs to develop and put the iASIC into production. The vertical scale is the total estimated lifetime volume of the iASIC and the horizontal axis is the approximate cost of the components being integrated. Where does your application fit?

Thanks to the iASIC, custom analog solutions needn't require mega-dollars or mega-units for justification. Stop wasting money today with off the shelf solutions. Your unique power management needs should reflect a uniquely low cost solution.

Fan speed control through digital power management

By Roberto Cappelloni

ALMOST A DECADE has passed since the first Digital Power Forum took place in San José, CA, on September 2004, and since then, the true digital power control and digital power management techniques have been gradually more and more adopted into the standard power supplies on the market. Although digital power control is gradually replacing the traditional analogue control loop, allowing the use of topologies and architectures not trivial to manage through analogue control, digital power management retains an equal importance in improving power supplies behaviour and reliability.

Adaptability is one of the main benefits of using a digital power management, and allows the end system user to experience a different and easier approach in respect to the previous technology. One example is fan speed control through digital power management, allowing an effective cooling while minimizing acoustic noise and enhancing service life, in real time, in any working conditions. When it comes to face the thermal management of a power supply installed in a system, and a cooling air flow is required to be produced by a fan, there are



Fig. 1: The DDP400 series front and top mounted fan versions power supplies from ROAL Electronics integrate digital control

several options to be evaluated from a pure design stand point. They can be summarized in three categories.

The most commonly adopted option prescribes the fan to be run at a fixed speed, close to its rating, no matter which the ambient temperature, output load and input voltage are. Once a fan is selected and its supply voltage defined, for a certain demand, acoustic noise and life time are almost determined, both being critical factors in a power supply application. To reduce

Roberto Cappelloni is EU Digital Power Business Development Manager at ROAL Electronics SpA - www.roallivingenergy.com

ANALOG INTEGRATION ISN'T FOR EVERYONE

www.maximintegrated.com

PLEASE STAND BY

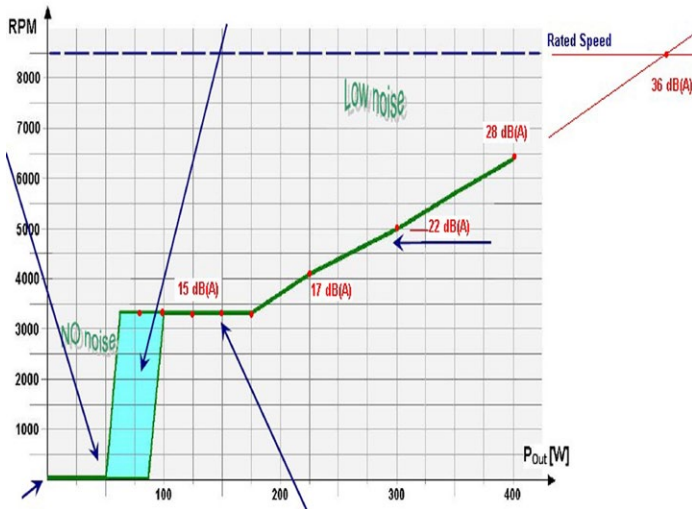

Fig. 2: The typical correlation between fan speed and output load at 230VAC and 25°C ambient.

noise and enhance life time while maintaining performance, it is common practice to oversize the fan. The unwanted side effect is a reduced power density of the power supply which, in turn, induces a lower compactness of the system that hosts it. In fact, to not impede the air flow for an effective cooling, a minimum clearance between power supply and system structure has to be maintained.

A second option is offered by using the so called self-controlled speed fan. The speed control function in these types of fans solely depends on the inlet airflow temperature measured through a built-in thermal sensor. The rotating speed is not correlated to other relevant variables such as the power supply input voltage and load. Although this option will typically allow a fan size reduction, it does not represent an optimum solution in terms of acoustic noise or life time along the whole working conditions range.

A holistic and less common option finally, involves a digital circuitry which produces a fan speed digital control function dependent on all three relevant variables: power supply ambient temperature, output load and input voltage from the mains. This digital control is integrated into the DDP400 series front and top mounted fan versions power supplies from ROAL Electronics – see figure 1.

The typical correlation between fan speed and output load at 230VAC and 25°C ambient temperature is illustrated in figure 2. The figure also highlights acoustic noise levels at various points of the characteristics. At no load, as the PS turns on, the fan starts up at maximum speed and then stops rotating after having completed an auto-diagnostic run which lasts only few seconds. The fan remains off as long as the load does not exceed 50W. Above the 50W threshold, the fan starts rotating at low speed (little higher than 3000 RPM) and in an intermittent mode, up to 100W. The On-Off duty cycle depends on the load level between 50 and 100W and the ambient temperature. Above a 100W load, the fan starts a steady low speed running up to 175W, unless the ambient temperature is such that it triggers a higher speed. Above a 175W load, the fan rotation speed increases with the load applied to the power supply. At maximum load the fan rotates at 75% of its maximum rated speed.

Figures 3 and 4 show how the RPM-Load characteristic is expected to change when increasing the ambient temperature above 25°C while maintaining the input voltage at 230VAC and, decreasing the input voltage below 110VAC while maintaining

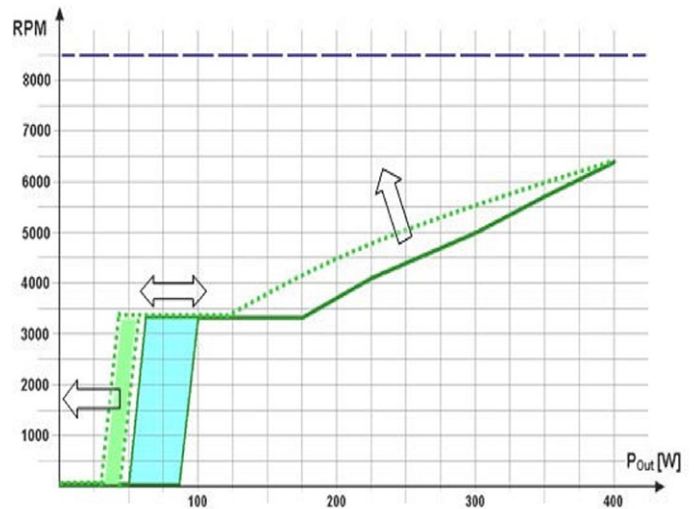

Fig. 3: T ambient increasing above 25°C, VIN=230 VAC.

the ambient temperature at 25°C, respectively.

Ambient temperature increase will cause the characteristic to translate towards the left, shrinking the On-Off cycle with an anticipated speed ramp up for higher loads. Decreasing input line voltage below 110 VAC has not a significant effect when the load remains below 30% of the supply's rated value; for higher voltage levels the speed ramp up will be more reactive. These two effects will combine if both temperature and input voltage increase, affecting the digital control. In all instances the fan's maximum speed will not exceed 6500 RPM (75% of its maximum rated speed), and it will always be adjusted for the optimum compromise between cooling, acoustic noise and fan life time.

Implementing this digital control function, the fan mounted variants of the DDP400 series do produce the exact amount of airflow strictly required for effective cooling, in real time, whatever the working conditions. As well as minimizing acoustic noise and extending fan lifetime, the operational region in which the fan is switched off, is interpreted by a 0 to 5V digital signal (0V when the fan is off, 5V when the fan is on). Easy to access, this signal can be used as a feedback for the system hosting the DDP400 unit. In some applications, this valuable feature enables the cooling system to be synchronized with the power supply.

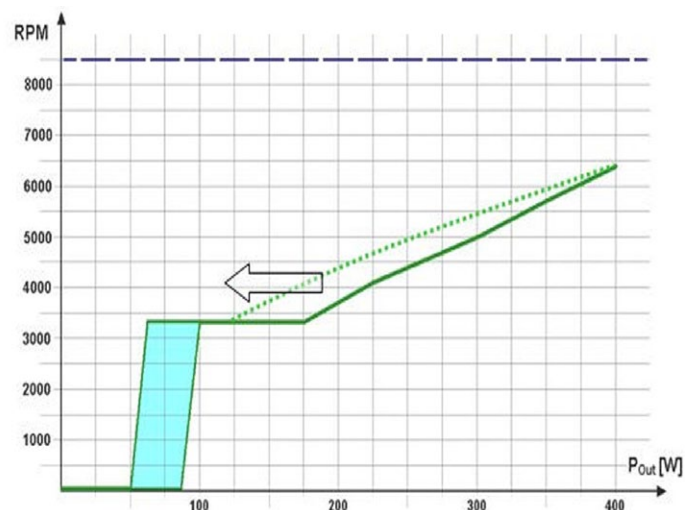

Fig. 4: VIN decreasing below 110 VAC, 25°C T ambient

The three essentials of RTL power optimization

By Mike Gianfagna

THERE ARE THREE ESSENTIAL components to optimizing power for today's and tomorrow's unprecedented and relentless consumer-driven power requirements: power reduction, power estimation and power verification. In the past, when we thought about power optimization, we figured that all we needed to do was shave a bit of power through the use of transistor sizing or process variants. That won't cut it anymore. Today, power reduction needs to be considered much earlier in the design process – at the register transfer level (RTL) or at the architectural level. Certainly, RTL power reduction is a critical component needed to help meet power budgets, but it is not enough. Chip designers need RTL power estimation and power verification, as well as RTL power reduction to correctly optimize power in their designs.

Power estimation helps you map your course to optimized power in your design. When you're traveling somewhere on unfamiliar roads, you'll have a tough time effectively navigating in this new territory without a good map, compass or GPS system. The same is true of power optimization. Without a good baseline of your design's current power consumption, it's hard to prioritize all the methods available for power reduction. Looking at the big picture is important. Solid, reliable and consistent power estimation will give you the GPS coordinates you need to find the best path to market. Sophisticated RTL power reduction techniques will present you with hundreds, perhaps thousands of options. But, which ones are the most fruitful to pursue? A good power estimator will answer that question for you.

And what about verification? Why is that important? Design engineers currently capture highly complex power intent in one of two standard formats – CPF or UPF. Engineers define power domains, and specify power management techniques so that downstream tools can automatically implement the intended power management method. But what if there is an error in the power

intent? What if your "golden" CPF or UPF isn't golden at all, but a major source of implementation errors? Not a pretty picture, if found during a two to three week place and route run. Beyond the obvious problem of longer time to market, bad CPF/UPF can negatively affect power estimation and reduction. Designs with multiple power domains need correctly expressed power management subsystems. Errors at this point in the process will slow everything down. Also, many CPF and UPF files are computer-generated, making the problem even harder to spot. Rigorous verification of this important information is critical.

So RTL power optimization is a threefold methodology: estimation, verification and reduction. You need all three for complete power management. Find a vendor who can support the entire process, and you will be able to meet the needs of consumers who expect the most optimized power in their mobile devices.

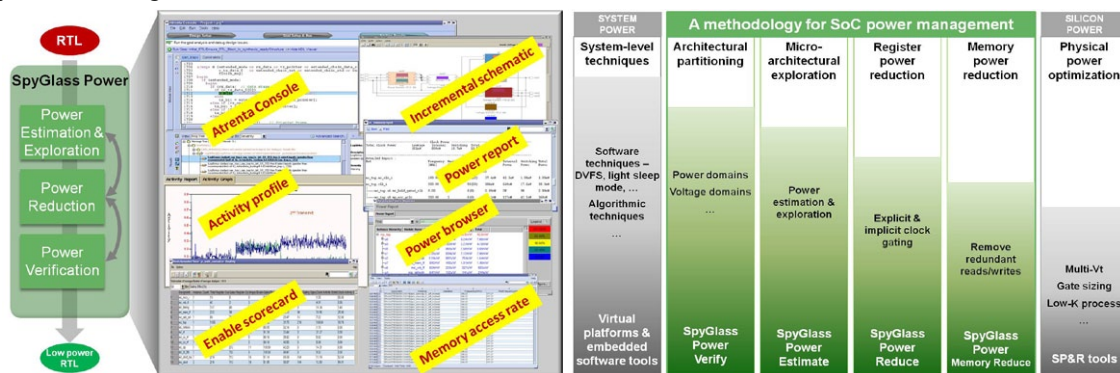

"RTL power optimization is a threefold methodology: estimation, verification and reduction"

EMCO
HIGH VOLTAGE CORPORATION

AG Series

Only 0.128" high!

PATENT PENDING

High Voltage Converters
100V-6KV

EMCO is setting a New Standard in High Voltage Miniaturization

- Surface Mount Package
- Input to Output Galvanic Isolation
- Meets RoHS and REACH Directives
- No External Components Required
- High Reliability, MTBF > 1,862,000 hrs per Bellcore TR-332

www.emcohighvoltage.com/pdfs/agseries.pdf

Mike Gianfagna is Vice President of Corporate Marketing at Atrenta – www.atrenta.com

Power-aware debug emerges

By Nick Flaherty

THERE IS INCREASING focus on the analysis and debugging of power in embedded designs and this is adding a new dimension for system developers. Moving from a rough power budget to analysis of the code linked to the actual power consumption, engineers can now click on power spikes to see which instructions are responsible and set power break points to debug code.

Silicon Labs has launched a power aware tool that can provide the power figures for its configurable microcontrollers to give designers the power consumption of the different blocks that are implemented. The Eclipse-based IDE and AppBuilder software for Precision32 MCUs include tools that enable developers to estimate power consumption and receive configuration guidance to minimize system power. The Power Estimator tool gives developers a top-level graphical view of how a Precision32 MCU uses power in active and sleep mode. The tool enables developers to adjust power usage at the onset of a project even without having development hardware. Power Estimator automatically updates the system design with configuration changes, allowing developers to optimize each mode for the lowest power. A companion tool, Power Tips, provides software configuration guidance that helps developers minimize current consumption. Power Tips automatically appears within AppBuilder when the cursor hovers over a configurable setting. This simple ability to see power optimization tips while configuring the MCU saves considerable development time.

“We have the hardware system with the information to set break-points at for example 1mA so we can do power aware debug,” said Keith Odland, director of marketing for microcontrollers at Silicon Labs. This is particularly important with the DC-DC converter integrated on the chip, says Odland, as the converter allows different parts of the device to use different voltage domains, from 1.8V for logic down to 1.2V for memory. This can then be accurately modelled in the software tool to optimise the power consumption.

“Independent power domains can be brought out onto the motherboard and using debug and capture in real time data while we capture the signal chain through the internal registers,” he said. “We are looking at the best ways to implement that level of granularity.”

Providing embedded developers with a comprehensive suite of tools is just as important as the MCU itself, says Diwakar Vishakhadatta, vice president and general manager of Silicon Labs’ Embedded Systems business. “To help make the embedded design process faster and easier, we have invested

in developing a rich set of free software and cost-effective hardware tools specifically designed to ease development, simplify low-power optimization and enable rapid prototyping,” he said.

While these tools are pitched as the first of their kind for configurable microcontrollers, there have been power aware analysis tools available for low power microcontrollers for many months. Debugging companies are now also producing probes that can attach to a prototype board to measure the current and link that information to the debug tool so that engineers can set break points based on the power figures as well as code conditions.

“We have seen tremendous interest for our power debugging technology,” said Stefan Skarin, CEO of debugger developer IAR Systems. “It shows that we are breaking new ground for designing low-power applications. We intend to keep innovating power debugging to provide developers with the best tools to develop low-power software for embedded systems.”

The iJet JTAG probe with the iScope supports two channels but IAR is working on probes to support nodes across a board, says Skarin. “This is an enabler rather than a product,” he said, “and there will be more granularity in the next version.” As a result power debug is becoming a key element of the design of systems based around microcontrollers and so is increasingly important to the silicon vendors as well as the tool providers.

“Traditional software development tools only address utilization of the first two design targets, but with the innovative power debugging technology, embedded developers also can now stay in control of power consumption,” said Ritesh Tyagi, director of product marketing, Consumer & Industrial Business Unit at Renesas Electronics America.

“The optimization of power consumption is an issue that concerns all types of systems, not just battery operated ones. In low-power operation modes where the processor is stopped, the consumption is directly linked to the hardware implementation. In active mode the power consumption efficiency is dependent on both hardware and software.

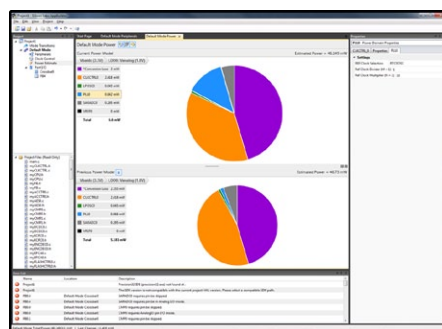
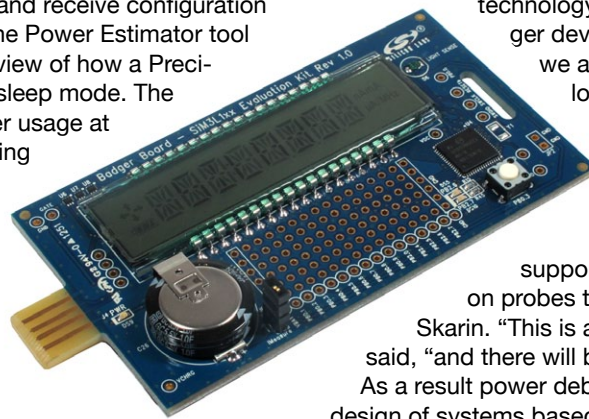

Silicon Labs Power Estimator tool using the AppBuilder software for the SiM31xx configurable microcontroller on its evaluation board.

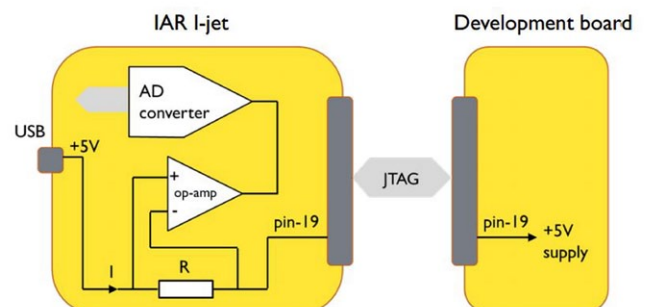

The iJet JTAG probe from IAR uses a digital-to-analog converter to provide power data from a target.

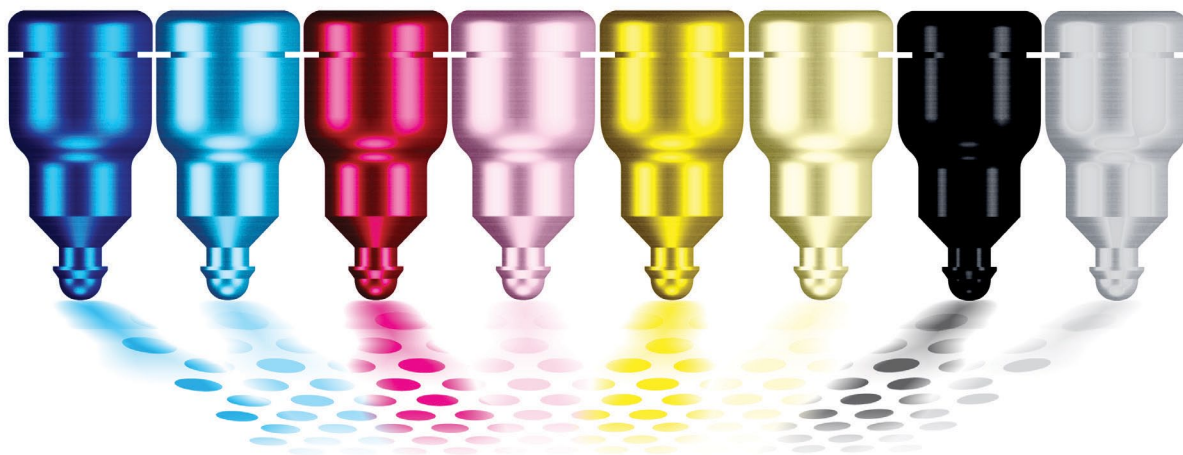

Space Saver. Cost Saver.

MP103FC Power Amplifier: Dual-Channel Design Delivers Space Savings, Cost Savings

DRIVE MULTIPLE PIEZOELECTRIC LOADS WITH SPEED, CURRENT AND VOLTAGE

The MP103FC from Apex Microtechnology is a dual-channel power amplifier that is designed to drive multiple loads with a single device. With full power bandwidth rated for 230 kHz, the MP103FC is optimized for industrial applications requiring piezoelectric loads with more than one driver. This thermally enhanced module also features output current of up to 15 A PEAK per channel and a 30 V to 200 V power supply. A single MP103FC delivers high current, high voltage and high speed at a per unit cost savings that makes it the option of choice versus single amplifier solutions and discrete designs.

- Print head electronic drives for industrial ink jet printers

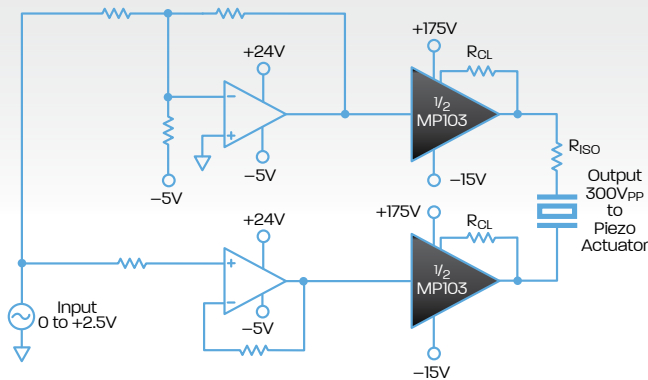

BRIDGE MODE PIEZOELECTRIC DRIVER
(For Design Discussion Purposes Only)

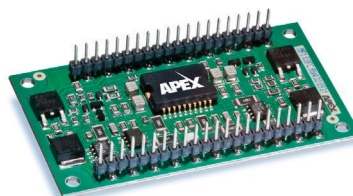

FC MODULAR 42-PIN DIP

Open Frame Product Technology
(actual footprint 65.1mm X 42.5mm)

Power up at www.apexanalog.com/eetemp103

apexanalog.com/eetemp103



The power debugger is a valuable tool that enables the customer to achieve aggressive power targets," said Jacko Wilbrink, ARM Product Marketing Director at Atmel.

But the way power can be debugged is also changing. "The way the tools are used at the moment it's in the latter stage of the product development where you will have the device that engineers are working to perfect, it's about squeezing down the power," said John Cornish, director of tools for the Keil part of ARM. "More things are starting to run on the host using Linux so people are starting to move more debug information up into the kernel rather than using the debug probe. "

Keil uses the DAQ data acquisition system from National Instruments to acquire the power data from boards that is then used by its DS5 debug tool says Cornish, but ARM also supplies a low cost two channel energy probe.

These join Energy Micro which has already emphasised its patented power aware tools that were launched back in April 2010 but needed more of an ecosystem of capabilities from the board to the software to be effective.

"As energy awareness is definitively an important aspect of code creation it is equally important that the development tools are able to reduce the debug and optimization efforts necessary," said Øyvind Janbu, CTO of Energy Micro. "The onboard Advanced Energy Monitoring (AEM) of our kits simplifies and enhances the functionality of the IAR power debugger tools."

The energyAware Profiler reads the AEM system data and provides simple graphical visualization and optimization of application energy consumption and code. Interfacing via USB with both the EFM32 Gecko development kit and the low cost starter kits, the patent pending profiler provides three simultaneous views; a graph of real-time application current consump-

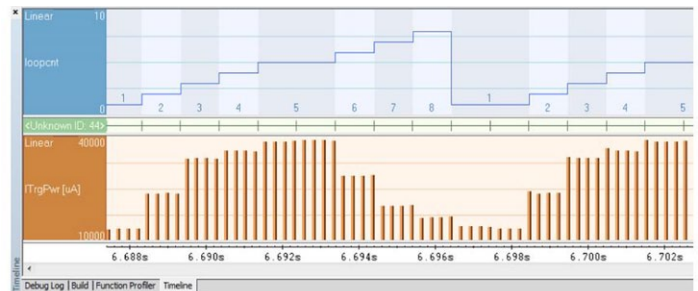

IAR's Timeline power aware debug interface linking code to power consumption.

tion, an object code listing and an energy profile of individual application functions.

Clicking anywhere on the current graph takes the user to the associated object code, highlighting the function responsible for the related current consumption. During code execution all application functions are individually profiled and sorted by overall energy consumption. The user can pause the real-time log at any time, scale and scroll-through the current graph and export data for further analysis.

"The energyAware Profiler is a significant step forward for the development of energy efficient code. Many weeks of debugging and optimization effort are quite literally translated into a short series of queries that deliver instant answers," said Janbu.

The need for more sophisticated power debug has not been lost on other microcontroller developers. UK multicore microcontroller developer XMOS Semiconductor is also looking at a low power version of its devices, along with tools for low power debug and analysis alongside its development tools. "I think we can do better than that," said CEO Nigel Toon.

Analog front end improves reliability of power line communication for smart grids

AnSem NV has released a flexible and low power Analog Front End (AFE) for power line communication (PLC) in the lower frequency bands. The ANS6201 is a single chip Analog Front End built in 0.18 μm TSMC technology that integrates

all main blocks, including filters, for a narrowband OFDM PLC transceiver. This integration, together with the single Power Supply of 3.3 V, reduces the Bill of Materials for a complete power line communication system. With a software defined approach, the settings of the AFE can be changed for optimal functioning in different frequency bands (10-500 kHz), under different protocols (ITU G.9955, G3, Prime, ...), under variable power line conditions. The ANS6201 can therefore be used in a wide range of today's applications, but is also future proof for changes in the protocols. The transmit path is composed of a 2 Msps 12 bit DAC, a 5th order filter and a PPA able to generate OFDM signals with an amplitude of up to 6 V_{ptp} compliant with the EN-50065 and FCC-regulation. The Analog Front End is controlled by a digital modem through a conventional SPI-interface. This interface can also be used to transmit and receive data between the AFE and the modem. The ANS6201 is designed for low power consumption, which is essential for smart energy applications. In receive mode, only 20 mW is required.

AnSem
www.ansem.com

2.0-A USB-ready Li-ion battery charger IC for fast charging portable devices

Toshiba Electronics Europe has launched a high-current USB ready Li-ion battery Charger IC, which offers one of the industry's fastest charging currents up to 2.0 A. Manufactured in the company's advanced 0.13 μm mixed-signal process technology, the TC7710WBG Charger IC supports cost, power and form-factor efficiencies for optimum charging of batteries used in smartphones and mobile devices. The device is designed with a highly efficient DC/DC buck regulator that handles up to 2.0 A of charging current in a compact WCSP25 2.5x2.5mm package. A 3MHz switching frequency reduces passive component value and, therefore, form factor, saving board real estate. The device can reach peak efficiency above 90%. The TC7710WBG was designed to protect system and battery circuitry. The input current comes from a 5 V USB adaptor and this voltage is delivered to the Li-ion battery through the device's switching regulator. It not only steps down the source voltage to the desirable voltage for the battery, but also controls the charging profiles dynamically to optimise the charging duration and operation reliability. An I²C interface allows various parameters such as charging current and profile selection to be set. The chip also supports the USB On-The-Go (OTG) standard to power a peripheral USB device (e.g. a pico projector) from the battery.

Toshiba
www.toshiba-components.com



60V LED drivers support up to 18 LEDs in series

Infineon Technologies has introduced two 60V DC/DC LED drivers for constant light output, with adjustable over-temperature protection. The ILD6070/ILD6150 drivers give lighting manufacturers the flexibility to produce multiple products using the same drivers, based on wide input voltage range from 4.5 V to 60V, adjustable output current of up to either 0.7 A or 1.5 A, and support of digital or analog dimming inputs, with a maximum dimming contract ratio as high as 3000:1. With the addition of 60V devices to its portfolio, Infineon enables manufacturers to support as many as 18 LEDs in a light string, compared to a maximum of 12 LEDs in typically available 40V devices. This helps manufacturers to lower costs or achieve higher lumens in a lighting system. The chips operate at up to 1 MHz switching frequency, which reduces manufactured cost and PCB space by reducing the size of external components needed in a design. Typical DC/DC conversion efficiency is up to 98 percent. Current accuracy of 3 percent across the full 4.5V to 60V input range contributes to exceptional stability of light output. The adjustable over temperature protection feature reduces light output when a threshold temperature is reached instead of turning off the light.

Infineon
www.infineon.com

12V-optimized zero voltage switching buck regulator

Vicor has expanded its Picor Cool-Power ZVS buck regulator product line with a device optimized for 12



V operation (8 V to 18 Vin) capable of delivering over 95% peak efficiency for 12V to 3.3V regulation and up to 15A. The PI34XX series buck regulators integrate a high performance Zero-Voltage Switching (ZVS) topology within a 10x14x2.6mm SiP and enhance point-of-load DC-DC regulation by reducing the switching losses associated with conventional hard-switching buck regulators. PI34XX series buck regulators integrate control circuitry, power semiconductors and support components within the SiP and require only an external inductor with minimal capacitors to form a complete DC-DC switching mode buck regulator.

PI34XX series buck regulators integrate control circuitry, power semiconductors and support components within the SiP and require only an external inductor with minimal capacitors to form a complete DC-DC switching mode buck regulator.

Vicor
www.vicorpower.com

Low power, high efficiency DC-DC converter

ON Semiconductor has introduced the LV5980MC, a 3A step down DC-DC converter IC that improves conversion efficiency at light load. The LV5980MC regulates input voltages from 4.5V to 23V down to an output voltage as low as 1.235V. The chip draws 63uA, with both pulse-width modulation and pulse-frequency modulation.

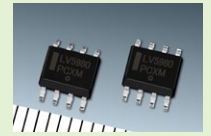

ON Semiconductor
www.onsemi.com



One less hat to wear.

Let us be your power expert. We understand that you don't have the time to master every aspect of electronic design. As a leading manufacturer of power supplies we are here to collaborate with you to ensure your next project is a success.



Novum®
Advanced Power



Ac-Dc
Power Supplies



Dc-Dc
Converters



www.cui.com/PowerExpert

NXP claims sound quality breakthrough with 9.5-V boost voltage in mobile micro speakers

NXP Semiconductors is launching a speaker driver IC that enables a 9.5 V boost voltage from an integrated DC/DC converter. Increasing the voltage headroom in the TFA9890 audio driver IC prevents amplifier clipping and keeps sound quality high at maximum volume. The TFA9890 safely drives a record 4 W of peak power into a standard 8-ohm speaker that is typically rated at 0.5 W, making a clear improvement to the sound output and quality of mobiles, tablets, TVs and portable speakers. Whereas traditional approaches have required cutting bass frequencies to avoid damaging the speaker, the TFA9890 builds on the advanced speaker protection introduced in the award-winning TFA9887 to enable safe operation while working at near-peak output at all times. The fully integrated protection includes adaptive excursion control, an approach that compensates for real-world changes in the acoustic environment. The IC measures current and voltage to the speaker, and uses the information to adapt the protection algorithm to account for changes like ageing, damage to the enclosure, and blocked speaker ports. The feedback-controlled excursion protection algorithm enables the TFA9890 – a single chip that includes NXP's CoolFlux DSP, a Class-D amplifier with current sensing, and a DC-to-DC converter – to provide nearly twice as much power into 8-ohm speakers, with sound output typically 6-12 dB higher than the TFA9887. In addition to increasing the speaker volume, the DC-to-DC converter's 9.5 V boost voltage improves sound quality by increasing voltage headroom and eliminating amplifier clipping. An advanced clip avoidance algorithm monitors audio performance and prevents clipping even when the power supply begins to sag. Bandwidth extension increases the low frequency response well below speaker resonance. Further, the intelligent DC-to-DC boost converter in the TFA9890 also prevents the audio system from causing battery under-voltage issues for the mobile device.

NXP Semiconductors
www.nxp.com

MOSFET driver IC offers enhanced protection and diagnostics for automotive applications

International Rectifier has introduced the automotive-qualified AU1R3200S MOSFET driver IC with comprehensive protection and diagnostic features offering enhanced reliability for relay replacements and battery switch applications. Available in an SO8 package, the AU1R3200S features over-current protection and over-temperature protection in addition to a diagnostic feature to report a short on the load.

When designed with two AU1RLS3034-7P power MOSFETs, an on-state resistance ($R_{ds(on)}$) as low as 0.75 mOhm can be achieved. The new device is qualified according to AEC-Q100 standards, features an environmentally friendly, lead-free and RoHS compliant bill of materials, and is part of IR's automotive quality initiative targeting zero defects.

International Rectifier
www.irf.com



Flickerless SSL LED driver optimized for commercial and wireless lighting

iWatt's digital AC/DC LED Driver platform is designed to address cost, performance and operating life in commercial and wireless solid state lighting (SSL) systems. The iW3630 is a two-stage, Flickerless LED Driver with output power up to 45W and is believed to be the first SSL LED Driver with a built-in 0V to 10V dimming interface for commercial lighting ballasts. It also supports a PWM digital dimming interface for wireless SSL applications. The highly integrated design of the iW3630 enables a 30% to 40% savings in bill of materials (BOM) cost compared to competitive solutions in 0V to 10V applications and, unlike alternative solutions, it maintains an extremely high power factor (PF) even at loads down to 20% of full load. It also offers a low total harmonic distortion (THD) of < 15%, to meet stringent global energy regulations, along with a built-in over-temperature protection (OTP) and derating function to improve the predictability and reliability of system operating life. The iW3630 achieves a 30% to 40% savings in BOM cost by integrating a number of design features. A built-in isolation transformer driver works directly with 0V to 10V dimming systems, eliminating the need for additional driver circuitry components and costly microcontrollers, while the PWM digital interface simplifies integration into wireless lighting systems.

iWatt
www.iwatt.com



Buck converter extends power scalability for smartphones and tablets

The DA9210 programmable multiphase DC-to-DC buck converter from Dialog Semiconductor can be scaled for use across multiple, high-end smartphone and tablet platforms. The four-phase buck converter delivers an output current of up to 12 A. This can be doubled to 24 A when two DA9210 converters are used in parallel and up to 38 A when combined with the company's DA9063 System PMIC to supply other power rails in the system. This makes the DA9210 ideally suited to high performance, ARM® Dual big-Little or Cortex A15 multicore application processors that enable consumers to multi-task using several applications simultaneously. Next generation processors are increasingly being architected to step between sleep mode and maximum load very rapidly to help minimise heat build-up. DA9210 supports this operation and delivers power with class-leading efficiency. The DC-to-DC buck converter delivers the highest level of efficiency across the entire output current range by selectively enabling and disabling phases, reducing losses by up to 50%. Further, it can increase the current supplied from zero to maximum in a millionth of a second to support very fast processor wake-up and application response times. By using this four-phase architecture, combined with a fast switching frequency, the DA9210 enables the use of very low profile components. The power management system, consisting of up to three ICs, behaves as one, simplifying the start-up configuration and power management control.

Dialog Semiconductor
www.dialog-semiconductor.com

2.8 to 80V input DC/DC converter with fixed output

A very high efficiency and an unusually wide input voltage range are the main characteristics of Linear

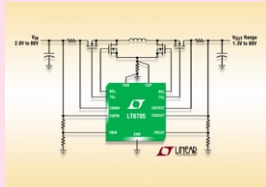

Technology's new LT8705 synchronous buck-boost DC/DC controller.

The LT8705 delivers up to 98% of efficiency, it has four feedback loops to regulate the input current/voltage, along with the output current/voltage. The output current loop provides a regulated output current for a battery Charger or current source. The LT8705 operates over a wide 2.8V to 80V input voltage range and produces a 1.3V to 80V output, using a single inductor with 4-switch synchronous rectification. Output power up to 250W can be delivered with a single device. Higher output power can be achieved when multiple circuits are paralleled. The operating frequency is selectable between 100kHz and 400kHz, and can be synchronized to an external clock. Users can select among forced continuous, discontinuous and Burst Mode operation to maximize light load efficiency. The LT8705 comes in a 38-pin 5x7mm QFN, and in a 38-lead TSSOP.

Linear Technology
www.linear.com

Power management front-end chip boosts battery run-time

Texas Instruments has introduced a single-chip, front-end power management unit (PMU) for battery-powered



applications based on ARM Cortex A9 and A15 processors. The TPS65090 power management

integrated circuit integrates all power management functions and maximizes power efficiency to extend battery run-time in portable electronics by 20%, simplify design, and reduce board space by 60% compared to a discrete approach. The innovative front-end PMU integrates a 4-A switching PowerPath charger, three 5-A DC/DC step-down converters, seven load switches, two always-on LDOs and a 10-channel analog-to-digital converter (ADC). The TPS65090 offers a 20-percent increased battery run-time by delivering up to 95-percent efficiency across 8-V to 12-V output voltages for two to three cells in series. The device integrates 15 functions into one front-end circuit to reduce the bill of materials and achieve a 60-percent smaller total solution than using discrete ICs. An integrated 4-A, multi-cell switching Charger helps to cut charging time in half. Power switches allow independent control of each major subsystem, and the 10-bit ADC accurately monitors power consumption.

Texas Instrument
www.ti.com

Power management chip embedded in PCB substrate

TDK has integrated a power management chip into the substrate of a PCB to reduce the size of its new multi-

channel modules. Based on TDK's SESUB technology (semiconductor embedded

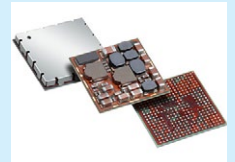

in substrate) and in combination with newly developed SMT capacitors and power inductors, this results in a space-saving footprint that is up to 60% smaller than discrete solutions. The module offers advanced multi-channel power management capabilities in a single miniature package measuring 11.0x11.0x1.6mm. The major features of the new power management module are its high-efficiency step-down converter Power Supply in a 5-channel configuration with a maximum output of 2.6 A, and its low-noise, low-loss voltage regulator Power Supply for up to 23 channels. A highly efficient lithium-ion secondary battery charging circuit is also included supporting currents up to 4A. The mixed signal IC integrates multiple Power Supply channels and allows command based control of output voltage and current. The module also includes a 16bit MCU with 256KB of flash for program memory and 8KB for data.

TDK
www.epcos.com

api 
technologies corp.
Spectrum Control

power film & dc link capacitors

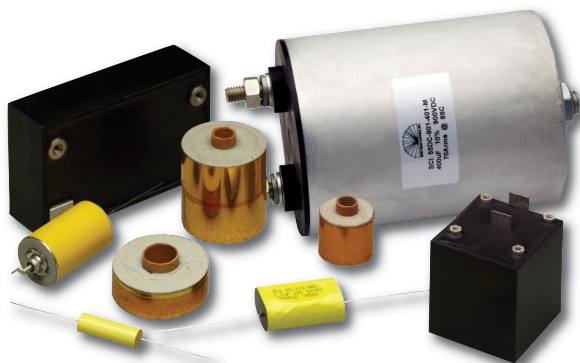

- High performance in rugged, Hi-Rel packages
- Maximum capacitance values – up to 10,000µF
- Low inductance, low ESR and ESL with low DF
- Voltages to 10,000VDC, ripple currents up to 400 Arms, 150°C operation
- Ideal for renewable energy power converters, off-highway vehicle traction control, electric vehicle battery chargers and many others

Call **49.9122.7950**
or visit eis.apitech.com/film

Download our NEW datasheet



EMI Filters • EMI Filtered Connectors • Advanced Ceramics • Power Filters & Capacitors • Magnetics

The challenges of designing medical devices

By Daniel Pfeifer

DESIGNING A PRODUCT FOR a medical application is probably one of the biggest challenges for a design engineer because of the confusing jungle of standards and guidelines. This article covers some of the most important aspects of designing a safe and compliant medical product that Escatec has learned during the process of becoming one of the few contract design and manufacturing companies to have achieved certification to the ISO standard for medical equipment – ISO13485.

Medical and technical advances are closely inter-related. New technologies allow greater levels of detailed information about the health of a patient to be obtained and thus open up new therapeutic treatment options. This progress leads to a steady increase of medical technology being applied on patients placing a responsibility on the manufacturer of medical products to ensure that products are extensively tested for technical security and reliability as lives depend on them. Furthermore, the risk-benefit ratio has to be constantly assessed during the development. Extensive verification and validation processes accompany the approval procedure.

An example of a medical product designed and manufactured by Escatec is the Twinstream multi-mode respirator for Carl Reiner GmbH – see figure 1. The challenge was how to design a ventilator for use when performing an operation on a patient's throat where the normal techniques of a pipe inserted into the throat would block access to the area being operated upon. Essentially the problem was how to pump air in and out of the lungs in an open system. It is rather like inflating and deflating balloon with a tube into the balloon open all the time through which instruments and lasers can move.

The Twinstream multi-mode respirator actually has two ventilators that operate completely independently with different frequencies and different pressures. The first provides the conventional 12 or so breaths per minute whilst the second provides a high frequency of around 800 breaths per minute. This second, high frequency ventilation reduces the stress on the lungs during lengthy operations that can take many hours, because it is very efficient at moving air in and out. This ensures that CO₂ is removed more easily, and oxygen reaches deep into the lungs to be more effectively absorbed into the bloodstream.

Risk management

The relation between patient benefit and risk has to be justifiable to the current state of the art. A risk assessment for every medical product has to be done, including the steps of analysis – risk assessment - mitigation - re-assessment – checking if the remaining risks are acceptable, then validate or look at the whole design again.

The risk assessment looks for risks for patients, users, third parties and the environment. Risks can appear during normal operations, in case of failure as well as during standby, storage or accidental damage. Everything that can cause a risk and the possible outcomes of these risks must be investigated and

documented.

The estimation of the probability of damage and the seriousness of harm for every single risk will be done after the analysis. If the classification does not show a justifiable risk, mitigation measures have to be worked out. The following principles should be applied in this order:-

- Eliminate or minimize the risks by intrinsic safety

- Take adequate precaution including warning systems for risks which can't be eliminated

- Inform the users about the remaining risks for which no appropriate (adequate) precaution could be found (training, user manual, etc.).

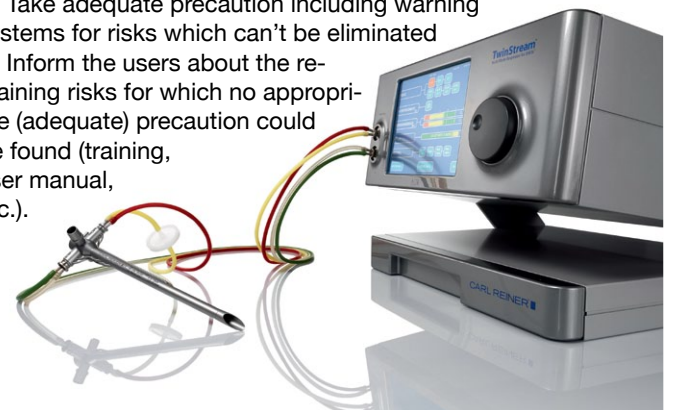
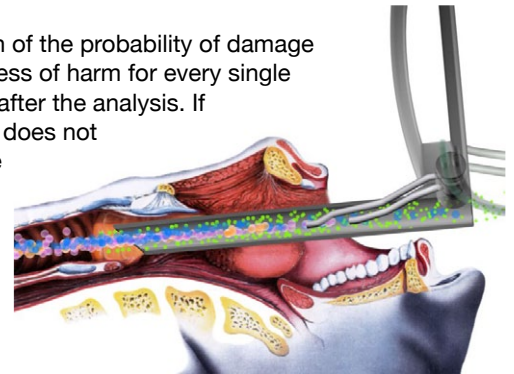

Fig. 1: The Twinstream Multi Mode Respirator.

If the effectiveness of the mitigation measures is verified, the remaining risk has to be assessed. If it is still too high, an adjustment of the risk mitigation is needed. A full cycle of the risk management cannot be completed until all risks are classified as "justifiable". It is necessary to repeat the pass cyclic during the industrialization phase of a medical product as well.

Basic requirements

The central standard for the development and the assembly of a medical product in Europe is the Guideline 93/42 EWG. The basic requirements are described in the appendix 1 of this guideline and the manufacturer and the distributor of a medical product have to adhere to the guideline. This can be done by respecting all relevant harmonized standards and regulatory directives and by an approval from the "notified body". Harmonized standards will substantiate the legal basic requirements and can be product-specific or describe general procedures and requirements.

It is not compulsory to follow the standards but is very advisable. The manufacturer has to prove sufficient safety and product performance according to the current state of the art in case of standard deviations or missing of appropriate standards. In single items, deviations of the existing standard may be impor-

Daniel Pfeifer is Global R&D Manager at Escatec
– www.escatec.com

tant – particularly for innovative products and technologies. The required clarifications, e.g. for validation or product comparisons can be very extensive.

Single paragraphs of the appendix 1 of the guideline should be analyzed and annotated with experience from practice.

General requirements

In item 1 of the general requirements, the following is mentioned: “Products have to be designed and produced in a way that the use of them will not endanger the clinical condition and the patient security or the user’s security and health or that of a third party, if they are applied for intended conditions and purposes, in which potential risks compared to the beneficial effect for the patient have to be justifiable and to be compatible with a high level of health and security protection.”

This general requirement is the basis of every development of a medical product and has to be checked during all product lifecycles. Under item 4 the following is mentioned:

“The attributes and performances of a medical product might not be modified in a way that the clinical status and the patient’s security and that of a third party will be endangered during the lifetime of the product if these products are exposed to forces which can occur under normal conditions.”

This paragraph mainly mentions the modification of the physical behaviors of electric and mechanical or pneumatic components and assemblies because of temperature, abrasion or aging. It is recommended to identify all working parts of a medical product to determine the service intervals and routine checks such as cyclical re-calibration or monitoring of the components for service indications. In this context, approaches such as redundant systems or diversification of problem solutions are a significant factor to make a medical product robust.

Because, in general, medical products have a longer lifetime than industrial electric devices, the aging effect of components have to be considered during the design process. A further aspect is the temperature variation during transport, storage, standstill and operation of the medical products. It is important to pay attention that the component specifications will not be breached during operation or storage and possible changes of temperature will be recognized and compensated for.

Requirements for the design and construction

A further important part of the guidelines is item 7.3: “The products have to be designed and manufactured to ensure that hazardous combinations of material and gases do not occur under normal application.” An exact study of the datasheets, especially in terms of toxicity, flammability and reactivity is needed. It is helpful to have information about the design details of already approved medical products.

Also item 10.1 needs attention: “products with measurement functions have to be designed in a way that, if considering adequate accuracy limits according to the functional specification, a sufficient constancy and accuracy of the measurement will be ensured.”

The basis for an accurate and robust measurement chain is the signal treatment as illustrated in figure 2.

It must have appropriate sensors, a low-noise amplifier (to take into account cascade effect), tuned filter stages (Nyquist-Shannon-Theorem to be considered). Further signal processing is often done in fully integrated micro-controllers, offering to change the sampling method and sampling frequency (see Nyquist-Shannon), analog/digital conversion (resolution, noise) and digital filtering.

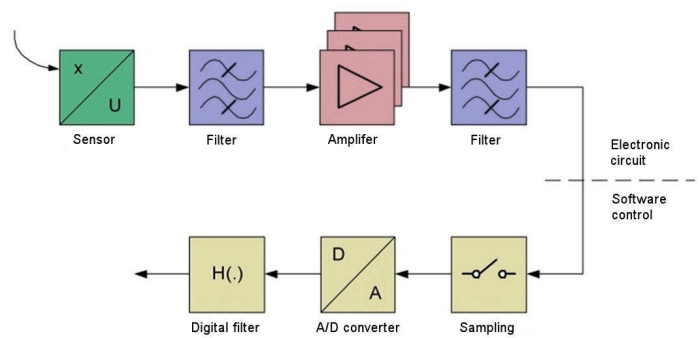

Fig. 2 Measuring signal process

Conclusion

Designing a medical product is one of the most challenging projects. Not only do you have to design something that is usually completely new so there is nothing to draw on, but you have to really think of all the possible scenarios of something going wrong and what happens then. If a consumer product fails, a consumer is inconvenienced. If a medical product fails, a patient could die. Fortunately, there are ISO standards and guidelines to help ensure that most eventualities are considered but this still leaves plenty of scope for designers to come up with creative and innovative designs that raise the bar of safety and patient comfort.

3D-PLUS
a HEICO company

Empower your Electronics

**32-bit DDR3
eMMC μ Solid State Drives
with
-55°C/+125°C Temp. Range
500 TC Assembly Qualification
for
Rugged Embedded Systems**

WWW.3D-PLUS.COM

What to consider when selecting medical device interconnects

By Anthony J. Kalajakis

TECHNOLOGY ADVANCES IN electronic consumer devices and the telecommunications industry are converging at a rapid rate with medical device technology. For example, the medical industry now embraces membrane switches from the appliance industry and relies on mobile phone interconnects within portable medical monitoring devices. In addition, super-precise surgical tools have been further improved by combining advanced fibre optic and interconnect design technologies.

Converged technologies like these have not only greatly enhanced the ability of healthcare professionals to provide direct patient care in clinics and hospital settings but have also helped monitor patient conditions remotely. In today's interconnected world, it is not unusual for healthcare professionals to consult with another healthcare professional in another city or around the globe. Increasingly, mobile communications are being used to monitor and coach patients with chronic conditions like diabetes.

Healthcare reform has also stimulated integrated approaches for patient diagnostics and real-time patient monitoring. Today's telecommunications systems provide the super highway for managing digital information as illustrated by Picture Archival and Communications Systems (PACS). PACS enables images such as x-rays and scans to be stored electronically and viewed on screens, creating a near film-less process and improved diagnosis methods. Doctors and other health professionals can access and compare images at the touch of a button.

But as medical device manufacturers further improve existing products and bring new products to market that take advantage of the latest technologies, engineers face conditions unique to the medical industry that make designing and manufacturing more challenging. This is particularly true in the current economic climate, where the pressure is on to deliver healthcare more cost-effectively. Whereas medical interconnects have traditionally been supported by specialty manufacturers, industry trends are increasingly leaning towards standards from other industries, such as consumer electronics and telecommunications.

The Molex circular MT expanded beam interconnect solution shown in figure 1 is one example of how advanced electronics are driving medical device innovations. When developing medical devices, manufacturers must consider durability and reliability to a greater degree compared to the consumer and telecommunications market. That's because medical devices are expected to last for many years, and in cases where devices are invasive to the human body, they must perform consistently

in relatively harsh environments. This is a real challenge as it relates to the use of industry-standard interconnects in the medical environment, where the form factor may be correct, but the materials and lifecycle may not match.

The need for 'modified-off-the-shelf' (MOTS) interconnects is a compromise of taking existing technology like a micro HDMI connector used in home audio/visual devices and perhaps ruggedizing it with different plating or retention features for use in medical devices. MOTS is where there is significant value for both the device designers and the interconnect providers – using prior components [I recommend this change because “prior art” is a term in the legal field with a specific meaning, and I'd rather not subject ourselves to potential issues for its use] at an 80 percent level, for example, can replace the need for a custom interconnect. When considering MOTS, it is beneficial to work with the company's application engineers to identify the risks and benefits of a particular interconnect solution.

The caveat is that many healthcare devices are attached on or into patients. In these cases, many medical device designers also face the extra challenge of providing functionality within small spaces with biocompatibility. In most cases, the medical device manufacturer will already have a pre-defined list of biocompatible materials that can be used. Although a part of this material definition is determined through regulatory bodies, since the responsibility of material choice relies on

the device manufacturer, there can be some pretty high-spec materials included.

The human body itself is a pretty stable environment, but once non-organic materials enter it, saline, blood and high humidity levels can cause serious corrosion and leakage. These biocompatible materials must also not react or be rejected by the body, so a material that has nickel in it, for example, must be avoided as a relatively high proportion of the population are allergic to nickel.

Metal alloys are predominantly used by medical device manufacturers including cobalt chromium, titanium, MP35N and stainless steel – 316L, in particular, has been tried and tested. Titanium, a very light-weight, strong and corrosion-resistant material, is commonly used in orthopaedic medicine for a hip replacement though is very expensive. MP35N is a conductive metal alloy that is highly resistant to the corrosive elements found in the body and is widely used for invasive cardiac applications. Medical-grade silicones have also become generally accepted for applications including defibrillator pads.

Micro engineering must conform to the need for devices, such as pace makers and hearing aids, to fit as comfortably as



Fig. 1: The medical circular lensed MT with tab.

Anthony J. Kalajakis is Strategic Marketing Manager Medical for Molex Incorporated – www.molex.com

possible within the human body. Again, the form factor could be in the correct scale, but biocompatibility and handling ease become the principle drivers. Due to the unique needs of the medical device market, there will always be a level of customization that requires a detailed specification (SPEC). SPEC-driven applications can benefit from previous designs from other industries with adjustments to the medical application requirements.

Thus, a key consideration for device manufactures is the choice of interconnects that make it possible to reliably transmit data, signals, images and power. The effectiveness of healthcare devices relies heavily on the underlying electronic interconnects with robust design and engineering that enable devices to perform as expected.

For medical devices, the interconnects must have secure contacts with high mating cycles, long lifetimes and durable materials to survive the rigors of everyday use in environments that can include a variety of fluids. Devices must also take into account possible accidental physical interference, such as hospital carts running over cables. In addition, interconnects must meet many other challenges and requirements, including tight signal integrity tolerances; a high number of mating and actuation cycles; and reduced losses due to resistance, stringent electromagnetic interference, radio frequency and crosstalk characteristics.

When choosing interconnects for medical devices, it helps to work with a manufacturer that has proven expertise in developing connectors that perform in harsh environments from other industries such as chemical, solar, manufacturing, pharmaceutical, military and telecom. These industries require some of the same rigorous attributes that the medical device industry requires, such as reliability, durability, flexibility, high speed copper or fibre-optic and small size, and manufacturers with experience in developing interconnects for such conditions typically offer a range of connector platings that ensure durability.

Working with medical device interconnects that feature all of these attributes is now more important than ever because of the critical nature of medical device performance. As electronics advance and merge, it is critical that the risks and benefits of interconnects be assessed with the device designer. Failure of a heart monitor, for example, carries much greater risk than failure of a smart phone or a router handling consumer phone calls.

And with the rising cost of healthcare significantly changing how patients receive treatment, and with in-home care becoming more common, the demand for smaller and portable medical equipment is likely to increase sharply in the coming years. Medical design firms will need to choose their interconnects wisely in order to meet this need effectively.

Molex has been delivering proven solutions to medical device manufacturers since 2005, and recently formed the Medical Connector and Cable Assembly Business Unit to directly address the increasing demand for advanced interconnect products in this market. A diverse range of products and solutions are available through the company's MediSpec portfolio such as the MediSpec hybrid circular MT cable and receptacle system shown in figure 2, or the plastic circular connector system featuring a low force helix contact design to provide a high-performance and affordable alternative to typical medical circular connectors. Molded interconnect device/laser direct structuring capabilities can be used to combine the versatility of the two-shot molding process and the speed and precision of laser direct structuring capabilities. This process can help medical device designers integrate complex electrical and mechanical features into highly compact applications.



Fig. 2: The MediSpec hybrid circular cable receptacle offers an integrated optical and electrical solution that reduces the number of connectors required in medical equipment and devices.

And with the rising cost of healthcare significantly changing how patients receive treatment, and with in-home care becoming more common, the demand for smaller and portable medical equipment is likely to increase sharply in the coming years. Medical design firms will need to choose their interconnects wisely in order to meet this need effectively.

The acquisition of TempFlex, a manufacturer of micro-miniature wire, cable and continuous coils using biomedical coating and medical grade base metals, further helps Molex develop technologies that provide medical device manufacturers with the maximum in product efficiency, reliability and flexibility.



1.4 MBytes/sec
Download

Emulator (J-Link™)

ARM/Cortex™ and Renesas RX

- Fastest Emulator Available
- Extremely Fast Flash Download
- Intelligence Inside the Emulator for Robust Communication
- Multicore Debugging Support
- Supported by All Popular IDEs Including CodeBench, CodeWarrior, HEW, IAR, Keil, Rowley, and GDB/RDI Compliant Environments



8.16.00 J-Link ULTRA
1.4 MBytes/sec Download Speed
The Fastest J-Link Debug Probe Yet!

The J-Link can be coupled with a number of available software modules to fit your application needs.

J-Flash is a standalone application used with the J-Link to program internal and external flash devices.

J-Link Flash Breakpoint permits you to set an unlimited number of software breakpoints while debugging in flash.

As the original manufacturer of the J-Link and its OEM derivatives, we are happy to inform you that this software also supports the DIGI® JTAG Link, Atmel® SAM-ICE, and IAR® J-Link KS.



49.98€
Special Offer

8.08.90 J-Link EDU
Educational Use J-Link
Includes Flash Breakpoints
Includes J-Link GDB Server
www.segger-us.com/edu.html

J-Link Educational Use (EDU) Bundle

www.segger.com

Using color sensors to diagnose skin diseases

By Frank Krumbein

COLOR RELATED SKIN conditions or alterations can be determined accurately using optical instruments. While in the past such skin color measurements were only possible in laboratories with expensive spectrometers or special measurement equipment, nowadays doctors can use handhelds based on multi-spectral color sensors.

The demand for precise color measurement in both the area of analysis using instruments for medical diagnostics such as point-of-care (POCT) and in dermatological research and applications, and especially for diagnostic documentation, is constantly rising. For example, in pharmacology - skin conditions or changes as a result of disease or environmental influences can be determined and documented via optical measuring instruments. The results of these measurements can be used both for evaluating skin diseases and for preparing treatment or assessing treatment success. Gray scale levels, colors and spectral data followed by a subsequent analysis, color and spectral algorithms as well as application-specific evaluation are the basis for a broad application of optical measurement methods in the field of diagnosis.

In the past, skin measurements could only be performed in laboratories with high-end and expensive spectrometers or special instruments. Nowadays it is possible to perform same or similar analysis applications, such as the measurement of solids or liquids based on multi-spectral color sensor technology. Thus the same performance is provided at much lower cost. Using a non-contact measuring system, skin diseases such as psoriasis and neurodermatitis can be assessed, based on the erythema degree and the skin type (taking erythema and melanin content into account) or skin redness can be determined during a patch/irritation test. Sensor tasks are also found in spectral skin analysis with (skin) color management as recommendation and

follow-up tools for prescribing medication. Multi-spectral sensors offer an excellent price/performance ratio for use in laboratory technical measurements or in "mini-laboratories" dedicated for example to evaluate test strips for clinical/chemical parameters such as glucose, ascorbic acid, keton bodies, protein, Ph values, blood, nitrite, leukocytes,

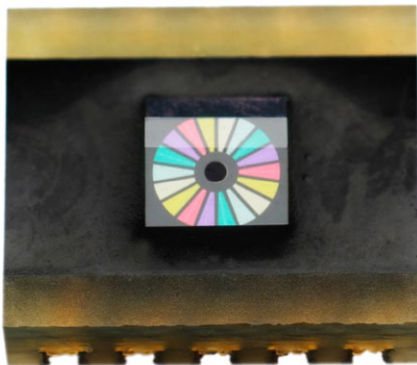

Fig. 1: The MMCS6 is a compact and robust multiple color sensor for precise color measurement in diagnostics. (Image source: MAZeT)

Frank Krumbein is Product Manager for Color and Spectral Sensor Technology at MAZeT - www.mazet.de

• Detection of metamerism

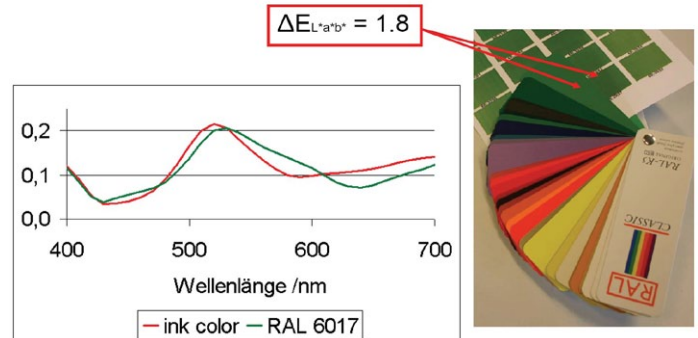

Fig. 2: Using the multiple range color sensors, the effects of metamerism can be measured, here using the example of two colors identical for human eyes (RAM sample and inkjet printout) with different spectrums measured by the sensor. (Image source: MAZeT).

bilirubin, and urobilinogen. Other possible fields of application include the spectral detection of medical and biomarkers such as in pregnancy tests, ovulation tests, diabetes, infectious diseases, and drug tests. Such spectral techniques can be used for microfluidic measurements to analyze fluid contents of medical or chemical cuvettes. In this method transmitted light reaches to a sensor while passing through the fluid contents. Spectral measurements are performed and based on a sample of reference water the spectral shift allows to determine various chemical contents and parameter within the measured sample. Using colour sensors, a reference application can be built into a compact handheld measurement device for microfluids. This allows the convenient measurement and data transfer to evaluation systems.

Color measurement methods

Color measuring tasks are performed in different ways. Tristimulus sensors are compact and optimized for large numbers and fast measurement tasks. Using an RGB filter, they are ideal for color detection. True color sensors with XYZ filter are suitable for absolute color measurement based in the CIE1931 standard for human eye perception. Both sensors work according to the colorimetric principle. Their results depend on the light source and are subject in relation to the effects of metamerism. Although spectrometers are very precise and independent of light, they are also expensive and usually very complex. They are slow due to their system and not suited for fast processes. A solution that combines the advantages of both technologies is more suitable - small like a sensor, robust and inexpensive, with the results of a spectrometer (highly precise and free of metamerism). Metamerism is the name of an effect in optics which creates the same color impression in people when objects with different spectral distributions look alike under the same light source. The multi-spectral color sensor MMCS6 takes this approach for specific applications in absolute color and spectral measurement. The sensor is based on 6+1 spectral/selective detectors. It enables fast, precise measurement of the spectral power density interpolated via 6+1 channels. The detector

supplies the measurement values, which are converted in the downstream amplifier and microcontroller directly in a color spot $xyY/La^*b^*/Lu^*v^*$ or optionally can be used as the starting point for spectral processing, depending on the application.

All-in-one: colormetric and spectral

The core of this color measurement equipment is a Jencolor color sensor from MAZeT, which carries out spectral measurements for medical and general applications. This multi-spectral color sensor closes the gap between previously used RGB sensors and spectral measuring devices for sensor applications. On a semiconductor base with thin optical layers, the sensor performs a spectral color measure-

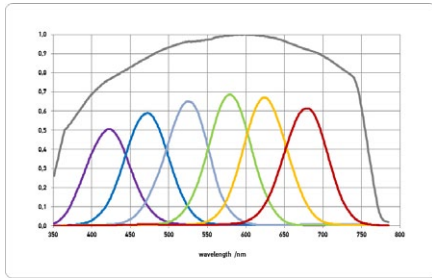

Fig. 3: Spectral curves of the multiple color sensor (Image source: MAZeT).

ment directly on the sensor – see figure 1 - using 6+1 characteristic spectral curves in the visible range VIS (Visual). The color is evaluated on the radiometric level. As a result, one obtains the spectrum of a color as with a spectrometer, which is then used for calculating the color spot within each color space. The advantages of such technology are that substantially greater information density is achieved in the measurement, which gives more precise results in the color measurement. Consequently, both results, spectrum and color spot are available for further analysis. The sensor therefore provides another advantage, in that metamerism effects can be filtered out and they are measurable in the measuring and evaluation of colors – see figure 2.

The six characteristic spectral curves of the MMCS6 are arranged in a way that they overlap at their limits. The

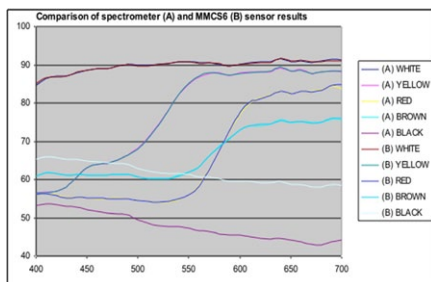
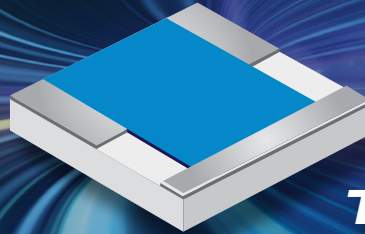

Fig. 4: Comparison of spectrometer and multiple color sensor results (Image source: MAZeT).

result is that the least possible number of gaps is present in the visible spectrum. Consequently, misinterpretations of colors are minimized and measurement accuracy is increased. MAZeT provides the MMCS6 as semiconductor sensor, including in combination with sensor signal amplifiers and as OEM hardware solutions with a comprehensive software library for highly precise and fast color measurement for handheld or in-line measurements. Evaluation boards are available for the first test measurements, which can then be processed with user-defined test software via a simple serial protocol. During the design-in phase, available tools simulate the calibration algorithms and lighting conditions to provide system optimization.



Temperature Variable Attenuators

TVAs from the recognized leader in high reliability resistive components offer:

- Case size 0.150" x 0.125" x 0.200"
- Choice of three temperature coefficient of attenuation (TCA) values: -0.003, -0.007, -0.009
- Attenuation values from 1-10 dB
- Planar design with solderable or wire bondable terminations
- Lower signal distortion, phase change and intermodulation compared with active circuit temperature compensation

When the mission is critical, choose *State of the Art.*



State of the Art, Inc.

RESISTIVE PRODUCTS

www.resistor.com *Made in the USA.*

2470 Fox Hill Road, State College, PA 16803-1797

Phone: 800-458-3401 or 814-355-8004 • Fax: 814-355-2714

E-mail: sales@resistor.com • Source code: 56235

QUALIFICATIONS ISO9001 & AS9100 • MIL-PRF-55342 • MIL-PRF-32159 • MIL-PRF-914

Implementing real-time geolocation for medical personnel and patients

By Dante I. Tapia, Óscar García, Ricardo S. Alonso and Michel Seyrac

WIRELESS SENSOR NETWORKS (WSN) are used for gathering the information needed by intelligent environments, whether in urban construction and Smart Cities, home and building automation, industrial applications or smart hospitals. WSNs make it possible to build a wide range of applications, such as control of energy costs, monitoring of environmental data, security and access control in buildings, as well as industrial and home automation, among many others. In this regard, telemonitoring (or sensing) makes it possible to obtain information about users and their environment, which is taken into account when offering them customized services in line with their environment status.

One of the most interesting applications for wireless sensor networks is real-time locating systems (RTLS). Although outdoor geolocation is well covered by systems such as the current GPS or the imminent Galileo, indoor geolocation needs further development, especially with respect to accuracy and the use of low-cost and efficient infrastructures. Real-time locating systems can be used to track people, assets and animals, to provide access control, wander prevention, for warning and alert systems, to control security perimeters or for resources optimization.

Companies need to use some sort of monitoring system to track their human and technical resources, and especially, to improve their security, efficiency and safety, as well as reduce occupational hazards. In this sense, user identification is a key aspect for adequate services customization and environment interaction. This way, the system can identify each user, know where they are, and automatically provide them with services, without actually requiring the user to initiate the interaction. With the appropriate integration platform, it is possible to visualize the location of all the resources in a company and see how they interact and collaborate.

A widespread technology used in RTLS is radio frequency identification (RFID). In this case, the RFID readers act as exciters continuously transmitting a radio frequency signal that is collected by the RFID tags, which in turn respond to the readers by sending their identification numbers. In these kinds of geolocation systems, each reader covers a defined zone through its radio frequency signal, known as reading field. When a tag passes through the reading field of the reader, one can conclude that the tag is in that zone. Locating systems based on Wi-Fi take advantage of Wi-Fi WLANs working in the 2.4GHz and 5.8GHz ISM (Industrial, Scientific and Medical) bands to calculate the positions of the mobile devices (i.e., tags). Then a wide range of locating techniques can be used to process the Wi-Fi signals and determine the position of the tags, including signpost, fingerprinting or trilateration. However, locating systems based on Wi-Fi present some problems such as interferences with existing data transmissions and the high power consumption by the Wi-Fi tags. Ultra-Wide Band (UWB) was

recently introduced to develop such systems. As it works at high frequencies (the band covers from 3.1GHz to 10.6 GHz in the USA), it yields very accurate location estimations. However, at such frequencies the electromagnetic waves suffer a great attenuation by objects (e.g., walls) so its use indoor presents important problems, especially due to reflection and multipath effects. ZigBee is another interesting technology to build RTLSs. The ZigBee standard is specially intended to implement Wireless Sensor Networks and, like Wi-Fi, can work in the 2.4GHz ISM band, but can also work in the 868–915MHz band. Unlike Wi-Fi, ZigBee is designed to work with low-power nodes and, unlike Bluetooth, it allows more than 65,000 nodes to be connected in a star, tree or mesh topology network. What's more, different locating techniques based on RSSI and LQI can be used on ZigBee WSNs (e.g., signpost or trilateration).

However, although significant progress has been made, at present there are few platforms that efficiently integrate both automation and indoor geolocation capabilities in the same infrastructure. Therefore, most deployments are limited by the pre-installation of infrastructure, and integrators have to face the decision of choosing between other technologies or adapting their existing systems and infrastructure.

To remedy this, the n-Core platform developed by Nebusens combines WSNs and RTLSs in a single infrastructure. The main features of the n-Core platform are its fast deployment and ease of use. The hardware layer (i.e., n-Core Sirius devices) is pre-loaded with a specific firmware whose functionalities can be accessed from any PC via an Application Programming Interface (API). It makes it accessible from different development platforms like C/C++, .Net or Java, among many others, without writing any line of embedded code, which greatly facilitates its configuration and deployment.

The API includes two engines: an automation engine that can read virtually any sensor on the market (e.g., temperature, presence, lighting, etc.) and act on a wide range of actuators (such

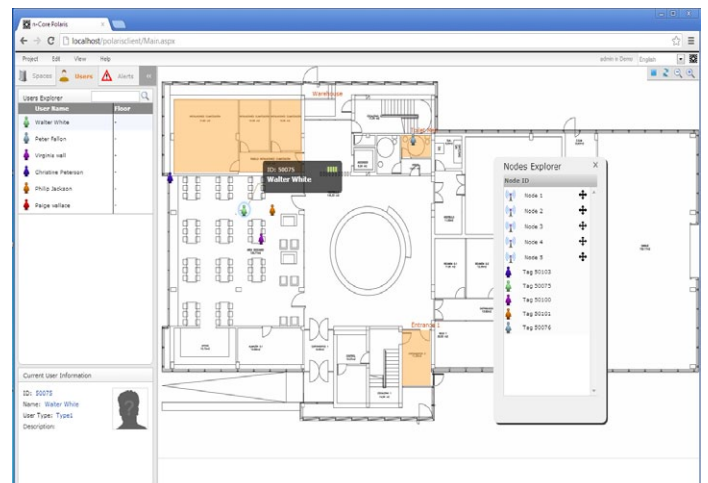

Fig. 1: Web-based interface of the n-Core Polaris real-time locating system.

Dante I. Tapia, Óscar García and Ricardo S. Alonso all work for Nebusens - www.nebusens.com
Michel Seyrac is co-founder of IIDRE automate - www.iidre.com

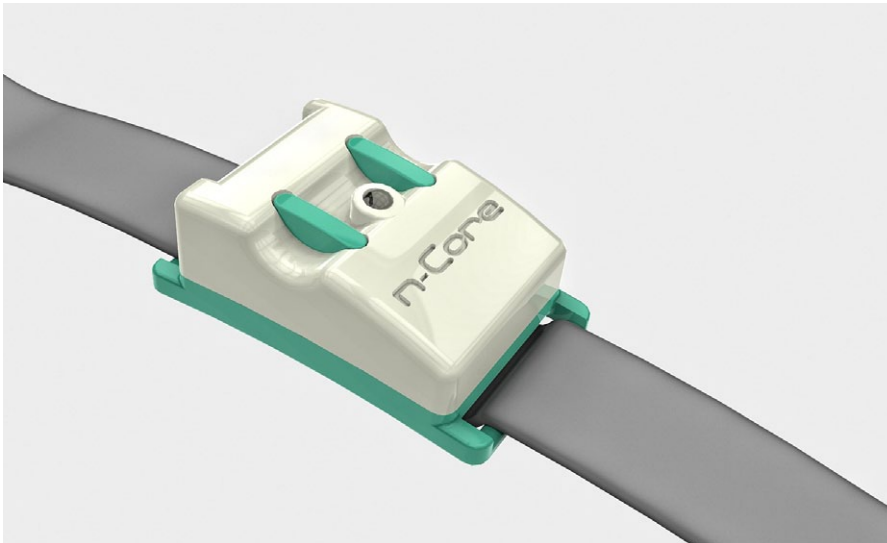

Fig. 2: n-Core Sirius Quantum used as a wristband tag with accelerometer features.

as alarms, sirens, electronic locks, etc.); and a locating engine which determines the position of mobile nodes (n-Core Sirius devices) using the same network infrastructure.

All n-Core Sirius devices are fully integrated with each other and can be interconnected with a wide diversity of sensors and actuators. Each n-Core Sirius device includes an 8-bit RISC microcontroller with 16KB of RAM, 4KB of EEPROM and 128KB of Flash memory and an IEEE 802.15.4/ZigBee 2.4GHz transceiver in a single chip (Atmel ATmega128RFA1). These devices have several communication ports (GPIO, ADC, I2C and UART through USB or DB-9 RS-232) to connect to distinct devices, including a wide range of sensors and actuators, as well as most existing computers. Thus, these devices can be combined to create flexible and scalable wireless network infrastructures.

n-Core Polaris is a full-featured automation and real-time locating system based on the n-Core platform – see figure 1.

It has a web-based architecture and it manages all the features of a system of this type: attractive GUI, user management, control of restricted areas, logs, alerting, etc. The n-Core Polaris RTLS has been successfully applied in healthcare facilities, one such example is the “La Vega” Retirement Home in Salamanca (Spain), where the system was chosen to sense and automate various areas of the building. In addition, the system locates residents at all times and therefore knows their behavior patterns in order to improve the healthcare assistance. In this residence, there is a locating infrastructure at the geriatric residence for positioning patients, medical personnel and assets within the building. The configuration used in the system consists of a ZigBee tag mounted on a bracelet worn on the users’ wrist or ankle (n-Core Sirius Quantum device), several ZigBee readers installed over protected zones (n-Core Sirius B devices), and a central workstation where all the information is processed and stored using the n-Core Polaris RTLS. These readers are installed all over the facilities so that the system can detect when a user was trying to enter a forbidden area according to the user’s permissions. The ZigBee network also provides information about the environment

thanks to different sensors, such as temperature sensors, light sensors, as well as smoke and gas detectors. n-Core Sirius Quantum devices are small enough to be carried by a patient, a caregiver or even an object, and provide a battery life of up to six months – see figure 2. The location of users is given as coordinated points obtained from the locating techniques provided by the locating engine of the n-Core API. Depending on the system requirements, several interfaces can be executed. The interfaces show basic information about nurses and patients (name, tasks that must be accomplished, location inside the residence, etc.) and the building (specific room temperature, lights status, etc.). The system allows users to keep track of any tag in the system as well as receive distinct alerts in real-time coming from the system in any Web-based device, such as PC or a smartphone carried by doctors and nurses. Among the different alerts there are panic button alerts, forbidden area alerts, as well as low-battery alerts.

The ZigBee infrastructure has been deployed in a 600 m² area within the residence where dependent people live with distinct dementias such as Alzheimer’s disease. The locating infrastructure is intended to provide the real-time position of people (i.e., patients and medical personnel) and assets (i.e., wheelchairs and lifters) with an average accuracy of 2 meters within the monitored area.

The infrastructure deployed for this 600 m² area includes 64 fixed ZigBee nodes acting as readers and collecting nodes, 15 tags for residents and nurses, as well as a location server running in a local computer. It has been demonstrated that indoor RTLSs improve the security and health care efficiency through monitoring and the automation of medical staff’s work and patients’ activities, facilitating the planning of working shifts and reducing time spent on routine tasks.

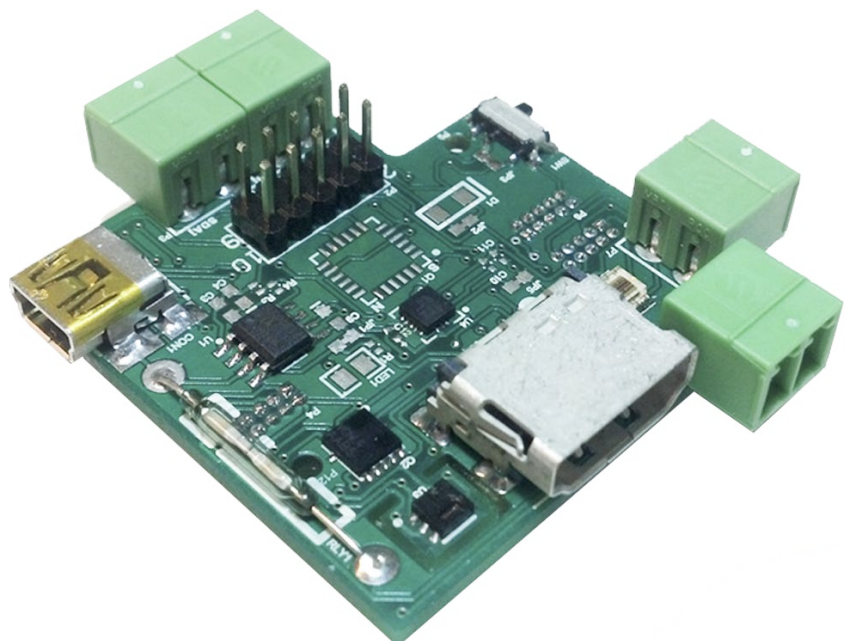

Fig. 3: n-Core Sirius IO sensor expansion board.

Patient-managed care and telehealth technologies drive medical design trends

By Greg Thompson

ONE OF THE most significant growth segments in the medical industry is devices used for patient managed care. These include a number of handheld medical devices that patients use to monitor their health and fitness. Another trend is the increased use of “telehealth” technology to link patients to healthcare providers using wireless or wired communication technology. Combining telehealth technology and personal-use devices for monitoring and communicating medical information has already shown significant potential for improved health benefits and reducing visits to a clinic or expensive hospital admissions.

The consumer electronics device that shares the majority of the core technologies making their way into medical devices is the mobile phone. At the core of a mobile phone is the RF technology that allows you to communicate wirelessly, a user interface consisting of a display and often a touch screen, low power electronics for extended battery life, Bluetooth connectivity and GPS. These same technologies are foundational for handheld-medical devices enabled with remote access telehealth capability. In addition to driving the technological features needed by modern handheld-medical devices, the mobile phone market has also driven down the cost of these core technologies.

Another aspect of medical devices that is just now coming to the forefront is patient compliance. This refers to being able to verify a patient is actually using a medical device or being able to verify they are taking medication as prescribed. Nearly

50 per cent of new medical devices being developed have a requirement to embed telehealth functionality in the device to facilitate demonstration of compliance. We also see a significant push toward using technology to monitor medication compliance.

But there are challenges associated with the broad deployment of wireless communications for medical devices. The first is the concern for privacy. Any time you store and transmit patient data, and this data can be associated with a particular individual, you must ensure the information is protected from inappropriate or malicious use. The second challenge is communications and data format standardisation and interoperability. Currently, there are no widely accepted standard data formats and communication that have been adopted by the medical device industry.

The main concerns with healthcare are safety, efficacy and in the practical world – cost. Medical devices can be made very safe using “smart” electronics. In a similar fashion medical devices can become more effective using “smart” electronics including advanced sensor technologies and very accurate and controlled treatments. Controlling the cost of medical care is

perhaps the area where smart medical devices can have the most significant benefit to society as a whole. The population of the earth continues to increase, the average life span continues to increase, and, unfortunately, the lifetime cost for healthcare is also continuing to increase. We believe it is only through the application of cost-effective technology that we can meet the needs of a growing population at a manageable cost.



“Nearly 50 per cent of new medical devices being developed have a requirement to embed telehealth functionality”

Greg Thompson is VP of Engineering at Sanmina Medical Division - www.sanmina.com

Low-noise, energy-efficient chokes for MRI scanners

SMP Sintermetalle Prometheus (SMP) has developed chokes for use in Magnetic Resonance Imaging (MRI). These inductive components are exceptionally quiet in operation as well



as being low-loss and energy-efficient. This has been achieved with magnetostriction-free materials that have been developed specially for use in medical equipment. These amplifiers supply output voltages and currents and control the gradient coils that encode the resonance signals for subsequent image reconstruction. The filter and mains chokes are designed to ensure a clean sinu-

soidal waveform and low-loss feedback of the unused energy. The chokes used in this application feature magnetostriction-free powder composites that have been developed by SMP for this purpose, and permit the construction of very low-noise chokes. This way, patients are not disturbed by loud rumbling and can continue to communicate with the medical staff. In order to make their time in the constricted, unaccustomed position as short as possible, the MRI scanner must be fast and powerful. SMP chokes are designed for frequencies up to 200kHz and currents as high as 1000A. They are available with diameters ranging from 36 to 300 millimetres and weighing from 50 grams to 130 kilograms. Protection types from IP00 to IP66 are available depending on the intended application. All components are compliant with RoHS and REACH restrictions, the materials used are UL listed.

SMP Sintermetalle Prometheus
www.smp.de

Low-power 32-bit MCUs draw as little as 350nA

The RX100 series is what Renesas Electronics Europe claims to be the industry's lowest cost, ultra-low power 32-bit RX devices, drawing as little as 350nA of current for embedded applications, with as little as 8KB of flash memory. The RX100 Series MCUs, which are based on the proven 130nm, low-power process technology, can run at 32MHz, delivering 1.56DMIPS/MHz throughput, consuming only 110uA/MHz power in full active mode and targeting only 350nA in the standby mode. This achieves an even lower cost and power consumption than the RX200 series already in the market. With this new series, the RX family provides a platform with a common core, using common tools and common peripherals. The RX100 series is clearly targeting low power applications such as wearable / battery powered applications including medical and sensor products. Due to the low system cost of the RX100 series, Renesas will also be able to compete very effectively in the ultra-low end market space where cost is the most important decision factor.

Renesas Electronics
www.renesas.eu



Low-power chip enables intra-cardiac ventricular fibrillation detection

Imec has demonstrated a low-power, intra-cardiac signal processing chip for the detection of ventricular fibrillation. An important step toward next-generation Cardiac Resynchronization Therapy solutions, the new chip delivers innovative signal processing functionalities and consumes only 20µW when all channels are active, enabling the miniaturization of implantable devices. Robust and accurate Heart Rate (HR) monitoring of the right and left ventricles and right atrium is essential for implantable

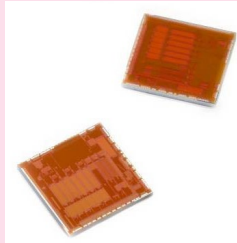

devices for Cardiac Resynchronization Therapy. And accurate motion sensor and thoracic impedance measurements to analyse intra-thoracic fluid are critical for improving clinical research and analysis of the intra-cardiac rhythm. Moreover, extreme low-power consumption is required to further reduce the size of cardiac implants and improve the patient's quality of life. Imec's low-power integrated circuit features three power-efficient, intra-cardiac signal readout channels. Each of the three electrocardiogram (ECG) channels is equipped with a precision ECG signal readout circuit with very low-power consumption and an analogue signal processor to extract the features of the ECG signal for detection of ventricular fibrillation. The feature extractor achieves only 2ms latency to facilitate responsive Cardiac Resynchronization Therapy. The low-power accelerometer readout channel enables rate adaptive pacing. To handle intra-thoracic fluid analysis, the chip also includes a 16-level digital sinusoidal current generator and provides 82db wide dynamic range bio-impedance measurement, in the range of 0.1Ω—4.4kΩ with 35mΩ resolution, with an accuracy greater than 97%.

imec
www.imec.be

Sports watch relies on optical technology to continuously measure heart rate

With the Mio Alpha sports watch, Nordic Semiconductor has unveiled what the company claims to be the world's first strapless continuous heart rate monitor for athletes. The sports watch employs a Nordic µBlue nRF8001 Bluetooth low energy Connectivity IC to communicate live or stored training data directly from the wrist to any Bluetooth v4.0 enabled smartphone or device. The Mio Alpha is designed for both serious amateur and professional athletes and employs a unique electro-optical cell with a pair of optical sensors on the underside of the watch to track blood flow volume in the wrist as it pulsates with the rhythm of the heart to extrapolate heart rate. An on-board motion detector and built-in noise filtration software developed by Philips compensate for arm movements and perspiration typical of fast running and cycling, which can all interfere with blood flow measurements. The watch's built-in rechargeable lithium ion battery offers up to 10 hours of 'live' heart-rate smartphone-linked monitoring (its most energy intensive operating mode). This ensures reliable performance even in demanding 2.4GHz operating environment.



Nordic Semiconductor
www.nordicsemi.com

contact@absopulse.ch
www.absopulse.ch

High-Performance, high reliable Power Supplies
15 W to 12 kW+ adapted to your challenging projects

- AC/DC Power Supplies
- Rectifiers and Battery Chargers
- DC/DC Converters
- Sine-Wave Inverters
- Phase and Frequency Converters
- AC- Input, DC-output UPS systems
- Open Frame
- Wall mount
- 19" Cassettes
- DC-input dimmable back-light inverters for LCD displays
- Complete Power Systems in 19" and 23" Racks

ABSOPULSE Marketing Europe GmbH
PoBox 1501
8620 Wetzikon CH
Tel. +41 78 896 50 49
Fax +41 44 944 38 44

Write us: contact@absopulse.ch
See us: www.absopulse.ch

Designing closed-loop MEMS-based capacitive inertial sensors

By Ayman Ismail

MICROMACHINED INERTIAL SENSORS have become an integral part of many consumer products, such as handheld mobile terminals, cameras, and game controllers. In addition, micromachined inertial sensors are widely used in vibration monitoring in industry, automotive safety and stability control, and navigation. In general, micro-sensors can be piezoelectric, piezoresistive or capacitive. However, the high thermal stability and high sensitivity of capacitive sensing makes it more attractive for a wide range of applications.

A basic capacitive sensor interface circuit, with digital readout, is composed of a capacitance-to-voltage converter (C/V) followed by an analog-to-digital converter (A/D) and signal conditioning circuitry. Operating the sensor, in an open-loop configuration (no feedback signal) results in a relatively simple system that is, inherently stable. Nevertheless, open-loop operation causes the system to be very sensitive to MEMS parameters. Moreover, the overall system linearity is affected by the linearity of each block in the sensor system chain. Also, the C/V and the A/D may need to satisfy challenging dynamic range requirements. On the contrary, enclosing the MEMS sensor in a negative feedback closed-loop has many benefits, such as improved bandwidth, and lower sensitivity to process and temperature variation of the MEMS device. Also, the C/V needs to only process the error signals. Therefore, the C/V dynamic range and linearity specifications can be relaxed compared to the open-loop mode of operation. Proper design of the feedback loop to ensure system stability is required.

In capacitive sensors, the feedback signal is applied to the MEMS in the form of a voltage signal on its capacitive actuating electrodes. The voltage applied generates an electrostatic force that acts upon the MEMS proof mass. Therefore, the resulting system is called a force-feedback system. However, capacitances have a quadratic voltage to force relationship, which imposes a limitation to system linearity.

One way, to overcome the burden of the voltage-to-force (V/F) quadratic relation, is to apply an actuation signal in a differential form, such that the quadratic terms are cancelled. However, this technique requires positive and negative voltage levels, which increases the complexity of the sensor interface ASIC. More important, the mismatch in the two actuation capacitances needed for differential operation, leads to incomplete cancellation of the actuation quadratic terms, and therefore capacitance mismatch limits the achievable performance.

Another way to implement closed-loop, depends on using a two-level, bang-bang feedback signal. Since, only two points of the quadratic V/F relation are exercised, this approach is inherently linear and does not rely on MEMS capacitor matching or using negative voltage for cancelling non linearity. The use of two-level actuation implies transforming the information in the feedback signal amplitude into information in time. Therefore, Σ - Δ modulation arises as an effective technique to implement closed-loop digital readout sensors. In addition, the Σ - Δ based loop provides implicit

analog-to-digital conversion, eliminating the need for a stand-alone A/D. Thus, Σ - Δ closed-loop architecture represents an optimum architecture for high performance digital readout sensors. It should be noted that the oversampling nature of Σ - Δ systems imposes an operating system at relatively high frequencies, and hence the system becomes more susceptible to coupling through the MEMS parasitic capacitances. Nonetheless, circuit techniques to cancel this coupling are possible and can be readily implemented in the interface ASIC of the sensor. The architecture selection of Σ - Δ closed-loop sensors is based on the deep knowledge developed for electrical Σ - Δ systems. However, system-level design and optimization of the Σ - Δ closed-loop sensors, which are of electro-mechanical nature, need a proper understanding of MEMS operation and modeling. The sensing part of a typical MEMS sensor behaves as a second-order lumped mass-damper-spring mechanical system, with a single resonant frequency, and hence, exhibits the following transfer function:

$$H_{mech} = \frac{x(s)}{F_{in}(s)} = \frac{1}{s^2 + \frac{D}{m}s + \frac{k}{m}} = \frac{1}{s^2 + \frac{\omega_0}{Q}s + \omega_0^2}$$

where $F_{in}(s)$ is the input force (Coriolis force in the case of gyroscopes or force, due to input acceleration, in the case of accelerometers). $x(s)$ is the displacement in the sensor proof mass, corresponding to the input force. m is the mass of the proof mass, D is the damping coefficient, and k is the spring constant (stiffness).

The principle of operation of a MEMS sensor depends on the fact that the input force (F_{in}) to the MEMS results in a certain displacement that alters the MEMS capacitance (C_{out}). This C_{out} can be measured by an electronic circuit that interfaces to the MEMS element. A MEMS sensor with actuation electrodes can be modeled as shown in figure 1. The model has a gain, $K_{x/c}$, representing output capacitance variation due to the MEMS proof mass displacement. $K_{x/c}$ is given by:

$$K_{x/c} = 2 \frac{C_d}{X_0} \quad \text{where } C_d \text{ is the MEMS detection capacitance, and } X_0 \text{ is the capacitance gap separation. The factor of two accounts for differential operation. The model, also, includes a factor, } K_{V/F}, \text{ which is the force generated due to fed-back voltage } V_{ACT}:$$

$$K_{V/F} = \frac{1}{2} \frac{C_a}{X_0} V_{ACT}^2 \quad \text{where } V_{ACT} \text{ is the actuation voltage and } C_a \text{ is the MEMS actuation capacitance. One important phenomenon of capacitive MEMS sensors is snapping (pull-in), where the capacitor plates stick together in response to a large applied voltage, causing operation failure. The maximum static voltage allowed, before stick in, is given by:}$$

$$V_p = \sqrt{\frac{8}{27} \frac{kX_0^2}{C_0}} \quad \text{where } C_0 \text{ is the rest capacitance of the capacitor. The expression above for } V_p \text{ is only helpful in showing } V_p \text{ dependencies.}$$

However, it is not accurate for determining the exact value of V_p , in the case of dynamic voltage actuation, as in a Σ - Δ loop. In Σ - Δ based sensors, the MEMS serves as the loop filter, resulting in a 2nd order electro-mechanical Σ - Δ system.

Ayman Ismail is Principal Engineer in the ASIC Solutions Division of Si-Ware Systems – www.si-ware.com; Cairo, Egypt – he can be reached at ayman.ismail@si-ware.com

Also, an electronic filter (Helec) can be introduced to the Σ - Δ loop to increase its order and suppress quantization noise further. The resulting Σ - Δ based sensor is demonstrated in figure 2, where a MEMS is interfaced to an Application Specific Integrated Circuit (ASIC) to form a complete sensor. The system incorporates an additional block Hcomp to compensate the loop and maintain its stability.

The system level design of the closed-loop sensor determines the optimum values for the MEMS and ASIC parameters such as stiffness (k), gap separation (X_0), damping coefficient (D), actuation voltage (V_{ACT}), and ASIC noise. For stable operation of the $\Sigma\Delta$ -loop, the input signal to the sensor cannot exceed the feedback signal. Therefore the value of actuation voltage, V_{ACT} , defines the maximum allowable input signal for a given set of MEMS parameters. However, generating a large V_{ACT} , to allow a high input signal range, results in a power dissipation penalty, and sometimes requires adopting special technology for the ASIC that allows high-voltage operation. ASIC technology selection can affect sensor overall cost. More important, the maximum value allowed for V_{ACT} is limited by the MEMS snapping voltage, V_p .

The MEMS gap separation (X_0) is a key parameter for achieving low noise operation. Reducing X_0 , leads to a higher C_d , and K_x/c . As a result, the MEMS forward gain (sensitivity) is increased. The high sensitivity reduces ASIC noise contribution to sensor input referred noise. On the other hand, the Brownian noise power of the MEMS is directly proportional to the damping coefficient (D). The total sensor noise is composed of the MEMS noise and the ASIC noise. The maximum tolerated ASIC noise can be estimated based on sensor target overall performance, MEMS sensitivity and damping coefficient. It should be noted that the minimum achievable X_0 is limited by the MEMS technology. The effect of X_0 value on the maximum input range depends on whether the actuation voltage (V_{ACT}) is limited by the snapping voltage of the MEMS or not. If V_{ACT} is limited by snapping then reducing X_0 can cause a

reduction in the maximum allowed input signal range. Otherwise, the actuation capacitance (C_a) and KV/F improvement with X_0 reduction results in a higher feedback force, and consequently a higher input range.

The stiffness of the MEMS element (k) is a vital system design parameter, since it can be readily controlled in the MEMS element, compared to X_0 , whose minimum value is a MEMS technology limit. The maximum achievable dynamic range (V_{ACT} set to maximum allowed value before snapping), is independent on the value of k to the first order, assuming that ASIC noise is dominating sensor noise. That

is because increasing k , not only reduces MEMS sensitivity and increases ASIC noise referred to the sensor input, but also allows increasing the feedback force with the same amount as this allows operation at a higher V_{ACT} . For the case that MEMS noise dominates sensor performance, then k should be increased to allow a larger dynamic range. While for the case that operation is not limited by snapping, it is beneficial to reduce the value of k so as to increase MEMS sensitivity and reduce ASIC noise contribution to the sensor noise. It should be noted that the value of k alters the resonance frequency of the MEMS element. In open-loop sensors the resonance frequency sets an upper bound on the sensor bandwidth, while for closed-loop systems that is not the case. Therefore, k can be set based on dynamic range and noise requirements.

The highlighted sensor performance dependencies on MEMS and ASIC parameters show that the system level design of closed-loop sensors exercises plenty of trade-offs, where ASIC noise budget, actuation voltage, power dissipation, and technology are highly dependent on MEMS parameters. Therefore, the co-design of ASIC and MEMS, based on the target overall sensor specifications, is the recommended way to reach an optimum sensor, in contrast to designing an ASIC for an already designed MEMS.

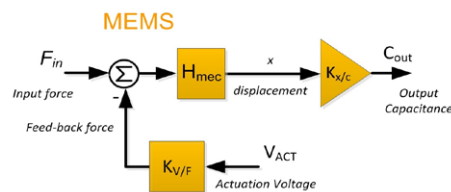

Fig. 1: Sensing part model of a MEMS inertial sensor.

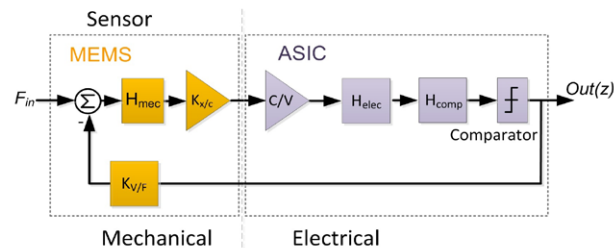

Fig. 2: Σ - Δ based closed-loop sensor.



DESIGNSPARK

NEW. FREE. MODELSOURCE

OVER 80,000 FREE SCHEMATIC AND PCB SYMBOLS IN MORE THAN 20 FORMATS, INCLUDING PADS, ORCAD, ALTIUM AND CADSTAR.

Discover today at www.designspark.com

UNIQUE RESOURCES BY 

MEMS accelerometers target healthcare applications

By Ulf Meriheinä

MEMS (MICRO ELECTRO MECHANICAL SYSTEM) technologies have become widely adopted for navigation and gaming applications through the design of MEMS-based accelerometers and gyroscopes, but another growing use for this miniature electromagnetic sensor approach is in healthcare.

One such popular application is for patient diagnostic equipment for measuring heart performance. The normal way of measuring the functionality of the heart is by measuring the Electrocardiogram (ECG) with a set of electrodes attached to or in contact with the body. You can measure a complex Vectorcardiogram (VCG), the classical ECG with amplitudes and timing of the P-QRS-T waves or just the timing of the R-peak, like in heart rate monitors or sports computers, as shown in figure 1.

The Electrocardiogram gives a lot of information about a larger variety of heart defects and diseases as well as about the state of recovery or physical and mental stress of the person measured. However, with ECG you cannot measure very well the mechanical pumping functionality or capacity of the heart. In addition the electrodes could disturb the patient's normal life by, particularly for leisure activity and especially for nighttime measurements. Fortunately there are complementary ways to measure the cardiac functionality, like ultra sound monitoring and ballistocardiology (BCG). The mechanical BCG signal follows the electrical signal with a delay of 30 to 40ms.

With ballistocardiology you can measure the mechanical motion of the heart by measuring force or acceleration from the chest, but another approach is to take remote BCG measurements of the blood pumping activity of the heart. With this remote measurement you can avoid attaching electrodes or devices to the body, an advantage for cardiac monitoring in everyday life situations. A single axis measurement in the length direction of the human being is normally adequate as this is the main direction of blood flow.

BCG offers good perspectives for application in preventive medicine, e.g. in detection of physical or mental stress or in the early detection of coronary heart disease. The amplitudes of the waves as shown in figure 2 are a measure of the heart's beat volume: from the timing one can see the general functionality of the heart as well as the heart rate and its variability, the latter describing very

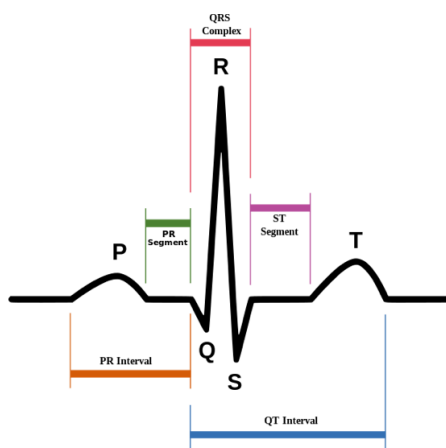

Fig. 1 - P-QRS-T waves in ECG.

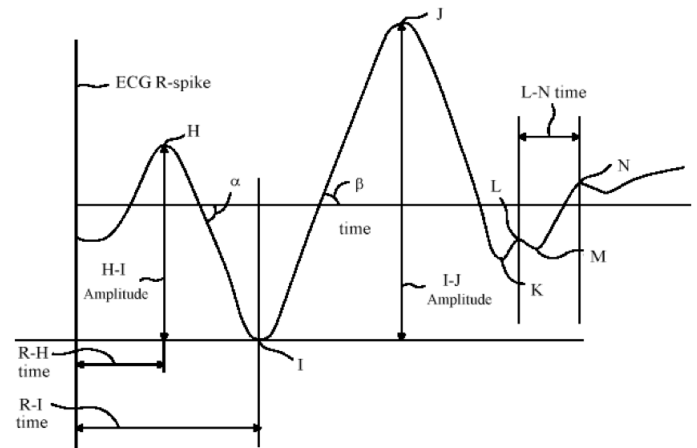

Fig. 2: The BCG waveforms.

well the recovery state or stress of the person undergoing the measurements. The I and J amplitudes in figure 2 can be useful in evaluating certain diseases such as aortic valvular disease or coronary artery disease, and even in predicting life expectancy.

Measuring the ballistocardiologic signal with an accelerometer includes engineering challenges such as the low level of signal acceleration relative to the noise from the sensor and the environment as well as the frequency response and resonances of the mechanical setup, which could be e.g. a weight scale or a bed. BCG from the bed is of particular interest as it enables sleep activity measurement in combination with physical fitness and recovery monitoring, which does not need electrodes and thus does not affect comfort or interfere with the sleep. This type of measurement finds applications in monitoring people with sleep problems related to physical or mental issues as well as in monitoring sportsmen for optimal training effect and

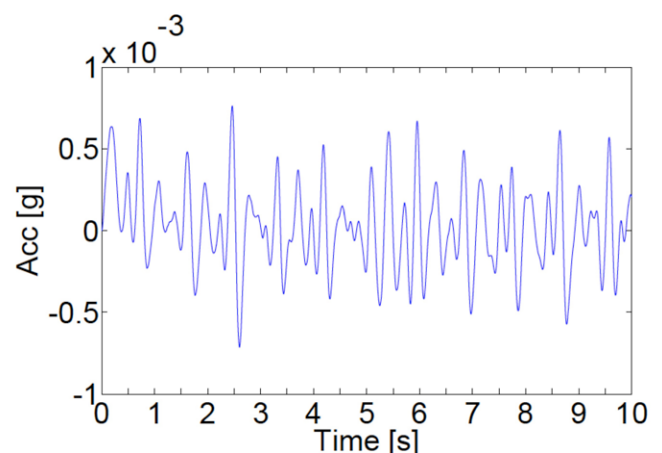

Fig. 3: BCG Waveforms from hospital bed measured with Murata's accelerometer SCA121T.

Ulf Meriheinä is Sr. MEMS Application Specialist at Murata Finland Oy - www.murataMEMS.fi/en

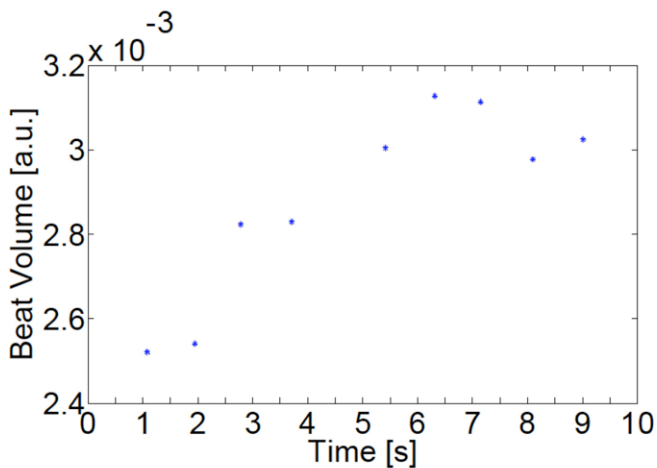

Fig. 4: Estimated beat volume.

avoiding overtraining.

In a recent design project, engineers from Murata studied patient activity in a hospital bed and separated that from the BCG signal. The residual ballistocardiologic signal measured from the bed platform is illustrated in figure 3. It shows that bed resonances affect the signal and its decay over time. A reliable measurement of the signal in the 10-3g (cm/s²) range requires a sensor with excellent resolution. One example of a suitable sensor is the SCA121T accelerometer from Murata, with a noise density of about 14µg/√Hz.

By using advanced filtering algorithms the BCG signal can be separated from the bed resonance effects and noise. The resulting estimated heart beats and beat volume are shown in figure 4. The beat volume is expressed in arbitrary units as the transfer function from heart beat to acceleration needs to be calibrated for an absolute value, e.g. in dm³. The beat volume variation in figure 4, not being too large, is also a fairly good estimate of the performance of the BCG measurement and the filtering and calculation algorithm.

The time intervals between beats in figure 4 are of course the Beat-to-Beat times and the Heart Rate Variability (HRV) can be calculated from them as well as the heart rate as a moving average – see figure 5. Murata engineers have also performed similar BCG measurements on a bathroom scale with the same accelerometer part SCA121T. Heart rate results are shown in figure 6.

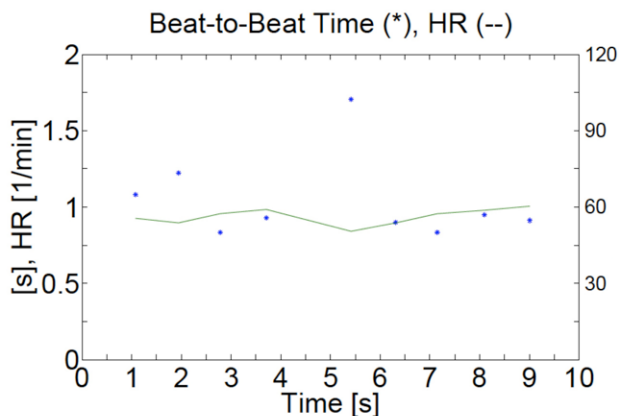

Fig. 5: Calculating Beat-to-Beat times and Heart Rate Variability (HRV) as a moving average.

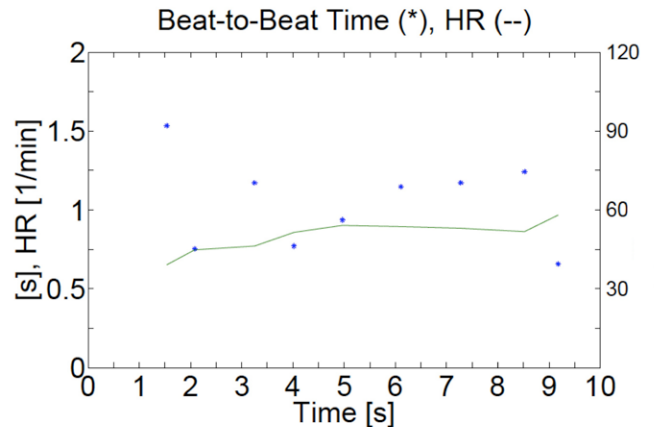

Fig. 6: BCG measurements performed on a bathroom scale with the SCA121T accelerometer.

The technology in a silicon MEMS (Micro Electro Mechanical System) sensor combines the best features and the smallest size, and involves etching (wet and dry), capping (wafer bonding & glass insulation), contacting (solderable and wire bondable electrodes). The example used earlier in the article is of the SCA121T sensor with a large proof mass which results from using the whole thickness of a silicon wafer. The device is capable of withstanding an extremely high shock in the order of 70,000g. Other key attributes include an over-range capability and the absence of any mechanical hysteresis or plastic deformation resulting from the use of a single crystal silicon structure. Stable capacitive measurement principles achieved with a large parallel plate capacitance coupled with high capacitance dynamics results in a MEMS sensor having an excellent signal to noise ratio.

When considering the design of a heart monitor based on the ballistocardiography approach, design engineers need to specify a sensor that has a noise density in the order of 14µg/√Hz, resulting in a measurement resolution better than 1 mm/s². The ability to avoid unwanted resonances is also critical, such as mechanical vibrations in a building. For this a sensor will exhibit a controlled frequency response, typically achieved by mechanical damping. Finally, advanced signal filtering algorithms should be employed by the sensor package to separate the actual signal from any spurious interference encountered in the operating environment. In case there is significant noise with a waveform similar to that of the ballistocardiologic signal, i.e. with amplitude, frequency and sequence in the same range, an additional accelerometer measuring the acceleration from the environment could be used for compensation of the signal. Hereby matching the phases of the two accelerometer signals is of high importance.

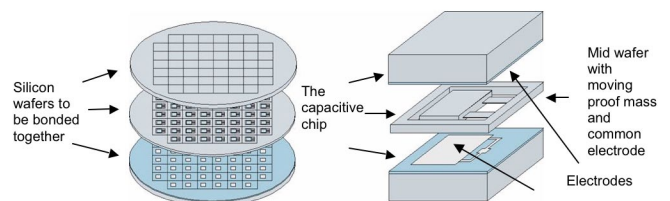

Fig. 7: Simplified picture of a highly accurate capacitive acceleration sensing element.

MEMS sensor signal conditioning for a thermal flow meter

By Marko Hepp and Bernd Schrörs

SENSORS FOR THE FLOWMETERING of mass, volume, or velocity use very different physical principles of measurement in order to satisfy a whole range of different requirements. One principle of flowmetering that is rapidly gaining acceptance is the thermal method, in which the transfer of heat in a liquid or gas is measured. In this procedure a heating element supplies a certain amount of heat and temperature sensors measure the heat distribution. This principle is well suited for miniaturization with MEMS sensors and for ASSP system integration. Low flow rates can also be precisely measured and controlled, as in medical applications, for example.

The fundamental mathematical principles of thermal flowmetering were devised 99 years ago by physicist Louis Vessot King who formulated King's Law for the calculation of flow velocity. The law describes that the amount of heat extracted from a heated wire mounted vertically in a measuring cylinder per unit of time is dependent on the average flow velocity and density of the gas or liquid. King's calculation assumes that the measuring cylinder is completely perfused and that the heated wire causes minimum disruption to the flow. As the diameter of the measuring tube is known, all that has to be defined is the flow pattern of the medium to be measured. With compressible gases it is necessary to also measure the pressure so that the volume (m³/s) or mass flow rate (kg/s) can be computed from the density. The heat output can be set to either CPA (constant power anemometer) or CTA (constant temperature anemometer). Typical MEMS flow sensors have one or two temperature sensors. Figure 1 represents a flow sensor with one heating element and one temperature sensor and illustrates the principle distribution of temperature of the flowing gas or liquid.

Figure 2 shows a flow sensor with one heating element and two temperature sensors in a setup where heat is distributed with no flow. Where a second temperature sensor is used, the flow can be measured in both directions.

Applying King's Law and a simplified equation, the rate of flow is calculated as:

$$\text{heat output PHe} = (\text{THE} - \text{TM}) \cdot (k_1 + k_2 \cdot \text{SN}),$$

where THE is the temperature of the heater and TM the temperature of the flowing medium. Specific constants k₁ and k₂ for each sensor are determined by calibration and S stands for the average rate of flow. Exponent N is ideally 0.5 yet and may also be in a range of 0.25 to 0.5, depending on the design of the sensor.

Flexible conditioning of sensor signals

Typical standard ICs are not sufficiently configured to operate and record the values measured by a flow sensor for the purposes of signal conditioning. The heating circuit must also be regulated and the existing sensor bridge circuits powered. Pressure must also be measured where the flow rates of gases are

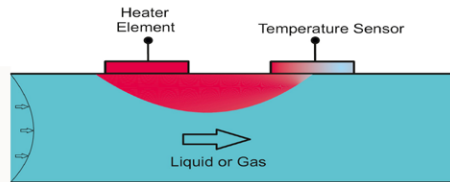

Fig. 1: Typical thermal MEMS flow sensor.

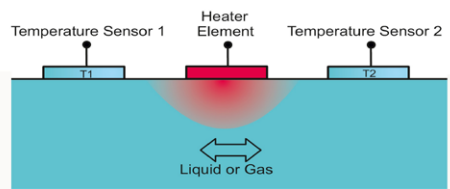

Fig. 2: MEMS flow sensor with two temperature sensors

metered to determine a volume. Universal sensor signal conditioning device iC-HO has been developed to handle with this complex task. The block diagram of figure 3 shows all the primary functional units necessary for a regulated heating circuit, sensor supply, and the signal conditioning path with linearization and an analog output. The analog output can be used to output the linearized measurement results as

a differential voltage of typically +4 V to -4 V.

The chip has a slave serial-peripheral interface or SPI so that it can be connected up to a microcontroller. This provides access to all of the programmable functions. The parameters and characteristic linearization data determined by calibration can be stored in an external EEPROM through the second SPI master interface. iC-HO reads out this data after power-up and validates the data with a CRC check. If this proves negative, the readout is repeated a maximum of three times. The device can also be initialized through the microcontroller after the automatic EEPROM reading has finished.

The temperature sensor in iC-HO supplies the chip temperature with a resolution of 1°C. An adjustable offset is automatically added to this. Should the MEMS sensor not have an ambient temperature sensor, the value computed on the iC-HO chip can be used as an alternative to correct the temperature dependency of the offset and sensitivity of the sensor.

iC-HO supplies the sensor measuring bridges and/or measuring resistors of the connected sensors with three current sources: SUS1 and SUS2 with 560 µA apiece for the constant current supply of a sensor half bridge and SUS3 with four settable values of 140 µA, 280 µA, 420 µA, and 560 µA for the ambient temperature sensor on the MEMS sensor. Current sources SUS1 and SUS2 have an excellent matching of typically < 0.1% across the entire temperature range.

In calibration mode, the sensor signal conditioner iC-HO can output the prepared analog signals at analog outputs OUTP/OUTN. This makes calibrating the gain and offset through the standard system interface a simple affair. The reference values needed to calculate the temperature of the heating element and the ambient temperature sensor are determined by automatic calibration which can be triggered through the slave SPI.

The signal conditioning path for SPIN/SNIN has a two-stage, programmable amplifier with $V = 1.1$ to 48 and a programmable offset correction. In operation the offset can be tracked automatically with the supply voltage or with the temperature. The

conditioned, differential sensor signal (ADP-AND in figure 4) is digitized by the downstream 11-bit A/D converter.

As shown in figure 4, this is followed by a range check with an adjustable upper and lower threshold and downstream digital temperature compensation of the sensor sensitivity. The sensor characteristics are linearized according to a lookup table (LUT). This contains the corrective values for up to 9 linearization points which can be freely selected across the entire A/D converter range. With a resolution of 8 bits the distance can be more or less set as required. The corrective value itself has a full 11-bit resolution. Linear interpolation then takes place between two linearization points. Output value DSENS in the lookup table is provided with a resolution of 10 bits across the digital interface and after D/A conversion at OUTP/OUTN. The measurement frequency of this path is 10 kHz. This makes it easy to also record states that change very fast.

Controlling the temperature

The two main modes of operation in flowmetering are as mentioned at the beginning of this article: the constant power anemometer or CPA method and the constant temperature anemometer or CTA method. Device iC-HO can operate on constant temperature regulation and differential temperature regulation as well as providing the heating element with a constant current supply. Figure 5 describes the heating circuit of a typical MEMS flow sensor with a heater and temperature sensor RBULK as a substrate measuring resistor, including a block diagram of the corresponding PI control unit and measuring circuit for the sensor signal conditioner.

The heating circuit current is controlled by a 12-bit D/A converter and can be set in units of 8.75 μ A from 0 to 35.83 mA. The heating circuit resistance is indirectly metered by measuring the voltage drop with a 14-bit A/D converter. A current source (typically SUS3) is applied to substrate resistor RBULK and the ensuing voltage measured by a 12-bit A/D converter. By using dedicated pins a full force and sense measurement is possible, which very positively affects the level of precision and stability of temperature. These values are calculated digitally with a resolution of 0.125°C using previously defined temperature coefficient TCR and stored current temperature reference values THACT or TBACT. The PI controller now regulates the heating circuit current to a constant differential temperature between THACT and TBACT which can be configured with a resolution of 5°C. If there is no RBULK present, the integrated temperature sensor can also be used for regulation. The repeat accuracy of the differential temperature control is of great significance to the precision of thermal flowmetering. With the resolutions used here, in particular that of 0.125°C resulting from the calculations of temperature, the expected accuracy of the entire sensor system across all parameters is considerably better than that of standard discrete solutions.

Combined with the configurable control of a temporal temperature profile, the integrated constant temperature controller is especially suitable for the operation of MEMS gas sensors.

Figure 6 shows the minimum system configuration, comprising the thermal flow sensor, iC-HO, and an EEPROM containing calibration data and the operational settings. The value measured is then output as a voltage at differential analog outputs

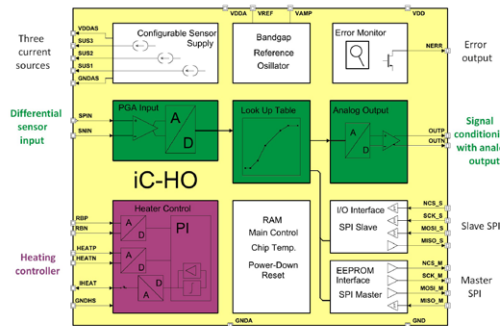

Fig. 3: Functional units for universal sensor signal conditioning in iC-HO.

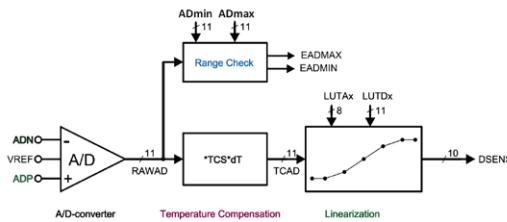

Fig. 4: Digital linearization of the sensor characteristics.

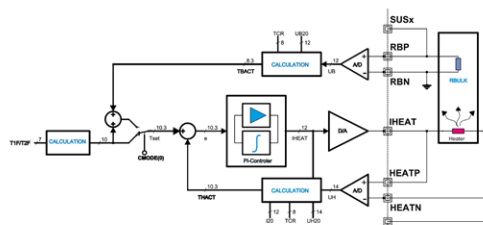
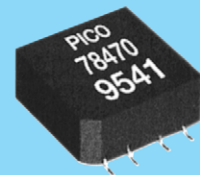

Fig. 5: PI heating controller for thermal flow sensors.

PICO

**SURFACE MOUNT
(and thru-hole)
Transformers
& Inductors**

**Size
does
matter!**



from
low-
profile

.19"ht.

- Audio Transformers
- Pulse Transformers
- DC-DC Converter Transformers
- MultiPlex Data Bus Transformers
- Power & EMI Inductors



See Pico's full Catalog immediately
www.picoelectronics.com

PICO Electronics, Inc.

143 Sparks Ave. Pelham, N.Y. 10803

E Mail: info@picoelectronics.com

Pico Representatives

Germany

ELBV/Electronische Bauelemente Vertrieb

E-mail: info@elbv.de

Phone: 0049 89 4602852

Fax: 0049 89 46205442

England

Ginsbury Electronics Ltd.

E-mail: rbennett@ginsbury.co.uk

Phone: 0044 1634 298900

Fax: 0044 1634 290904

OUTP/OUTN. This is proportional to the measured flow and typically between +4 V at a maximum flow in one direction of flow and -4 V in the opposite direction or without flow. The flowmetering system in Figure 6 also depicts an optional microcontroller with a display. This can digitally read out and display the measurement values from the sensor signal conditioner. For digital transmission through an IO-Link a transceiver, like the iC-GF is required which then also contains the analog and digital voltage supply. iC-HO requires a typical 90mW of power in idle mode, to which the power required by the MEMS sensor, and especially the heating element, must be added. Single measurement mode can also be implemented using a microcontroller and a power switch. The reduced measurement frequency then drastically lowers the amount of power consumed. iC-HO's startup time with an EEPROM is 1.6ms, after which the controller begins operation and measurements can be retrieved. As standard MEMS sensors have thermal time constants in a range of up to 10ms, the delay between startup and receiving the first valid measurement depends on this time constant.

Should an error occur in the sensor signal conditioner, the microcontroller can analyze this and pass on details to the higher control level. The flowmetering system can also be pa-

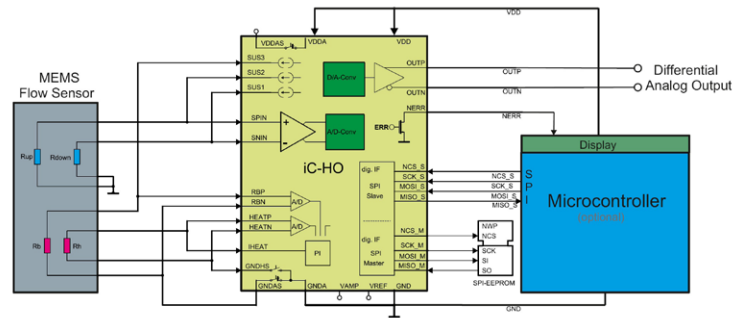

Fig. 6: Flowmetering with or without a microcontroller and an analog output.

rameterized through an IO-Link if servicing is required.

The thermal flowmetering of liquids and gases using integrated universal sensor signal conditioning reduces the amount of evaluation circuitry required by the sensor to a single IC. Various MEMS flow sensors can be evaluated bi-directionally using the precise CTA method of measurement. Thanks to the high level of integration cost-efficient flow meters can be implemented for remote industrial applications with 3-4 ICs. For small flow sensors embedded in medical equipment, for example, two ICs are sufficient. In gas flowmetering the pressure can also be measured in addition to the determination of volume and mass, reducing both the system costs and space required. The typical reaction time for a measurement is approximately just 100 μ s.

MEMS shrink gas chromatography

By Julien Happich

Founded in 2011 by Leti and the California Institute of Technology (Caltech), startup Analytical Pixels (APIX) is now sampling its first commercial and very compact portable gas chromatography device dubbed GCAP. The instrument relies on the fine assembly of a functionalized nanoelectromechanical system (NEMS) sensor array, a silicon-based MEMS microfluidics gas column and micromechanical silicon valves to be used as injectors. Control electronics and analytical instrumentation complete the picture to read out the NEMS sensor array's response to chemicals and enable parts-per-million detection accuracy.

The GCAP which is now sampling for beta testing is aimed at advanced gas analysis and biomedical screening but it could find applications in process monitoring, energy distribution, safety and security and in environmental control.

At the core of the GCAP is a NEMS resonator array consisting of vibrating functionalized actuators, in the shape of "diving-boards" fabricated from silicon carbide. Each diving board features a thin metallic gold film surface layer which is used as both a self-sensor and self-actuator of the device's resonant motion. The individual devices

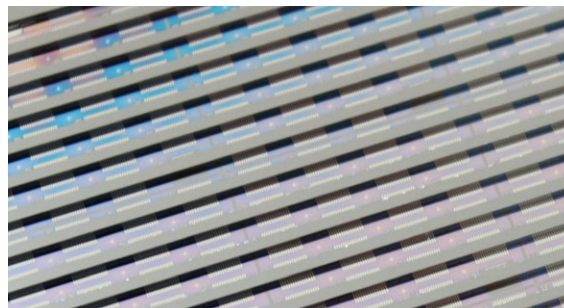

Fig. 1: NEMS wafer, post capping and pre scribing.

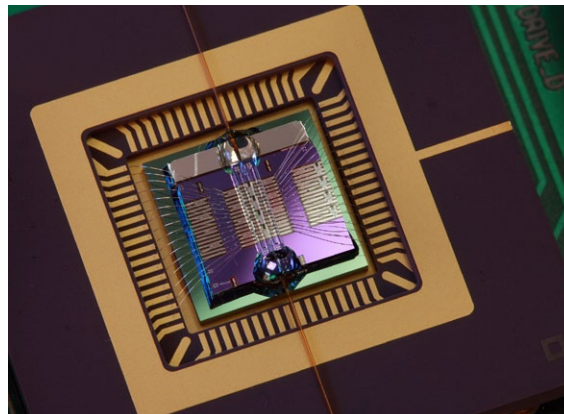

Fig. 2: Fluidic NEMS in chip carrier with the fluidics connection to the silicon GC column.

have active surface areas on the order of 1 μ m². According to Analytical Pixel, they can detect absolute masses below 1 attogram (10⁻¹⁸g). These NEMS sensors also have extremely high resonant frequencies, extremely fast response times (on the order of 10's of poseconds), and can be surface-functionalized to have their chemical selectivity tuned.

The NEMS resonator arrays are built using standard top-down lithographic fabrication techniques which allows for cost-effective batch fabrication in large volumes. A full array die is about 5mm across – see figure 1. The capping of the fluidics channels is done collectively using wafer on wafer sealing. The NEMS can then be connected to standard capillary tube inlet/outlet and to a gas microcolumn – see figure 2. The gas chromatography column through which the spatial chemical separation of the gas mix occurs is also a proprietary design in silicon, in the shape of a compact capillary coil built using standard MEMS processes – see figure 3.

Upon exiting the column, the gas reaches the packaged NEMS sensor chip which receives the separated components and records chromatographic peaks as frequency shifts in time. APIX has demonstrated that in this

configuration, the NEMS sensors could detect analytes below the parts-per-billion (ppb) level, and could resolve separation of over a dozen separate analytes within a four second analysis period.

What makes this gas chromatography solution particularly versatile is that the GCAP works with scrubbed air as a carrier gas instead of having to use bottled gases. This simplifies in-situ deployment for nearly real-time analysis while drastically reducing the operating costs. The very compact device requires less than 10 microliters of analyte and less than 1 milliliter of carrier gas to perform a chemicals analysis, under one minute. Depending on the architectural configuration of the NEMS array used, the GCAP can separate and precisely quantify individual molecules among hundreds of interfering substances.

Aiming at volume manufacture for full scale commercialization, the company has demonstrated batch manufacturing of the packaged NEMS array modules on 200mm wafers. It can also fabricate the MEMS-based silicon gas chromatography columns collectively and the MEMS-based piezoelectric valves to drive the analytes – see figure 4 – are fabricated on 200 mm silicon wafers with 90% electrical yield. In the future, this could lead to fully silicon-based microinjection systems.

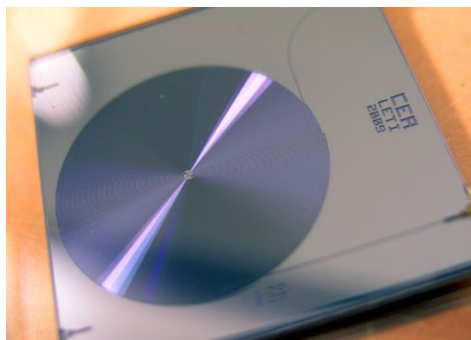

Fig. 3: The silicon chromatography column designed as a compact capillary coil.

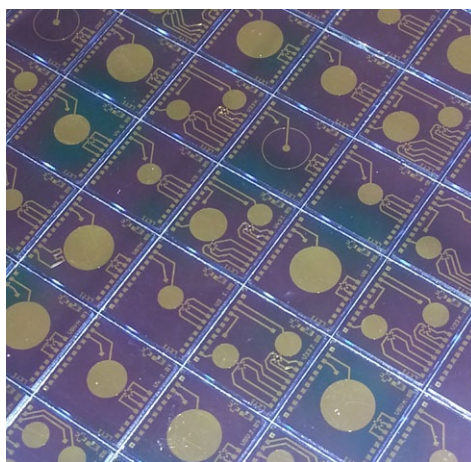

Fig. 4: A multi-die wafer with micromechanical silicon valves to be used as injectors.

Audio engines combine with MEMS microphones

STMicroelectronics together with Soundchip, has introduced two High Definition Personal Audio (HD-PA) audio engines, STANCO and STANC1, and an HD-PA microphone, the MP34AB01H, which enable the creation of feature-rich, software-controlled smart audio accessories. The STANCO and STANC1 HD-PA audio engines are designed to regulate the sound performance of over-ear, on-ear and in-ear headsets. The MP34AB01 is a compact 3.76x2.95mm analogue, bottom-port, HD-PA-compliant MEMS silicon microphone designed specifically to be combined with ST's HD-PA audio engines, with a flat audio response between 20Hz and 20kHz.

STMicroelectronics
www.st.com



Clip mounted tri-axial accelerometer

DJB Instruments has released a tri-axial accelerometer primarily for use in structural and modal testing. The AT/13 has slotted sides and a slotted base to allow it to be mounted on 5 of its faces by sliding into the accompanying clip. Users can then mount the clips using normal glue methods and slide the accelerometers in and out of the clip as required. This ensures perfect repeatability for tests without the need for leaving the accelerometer in situ. For large channel count testing, all accelerometers can be mounted in the same orientation making software set up easier.

DJB Instruments
www.djbinstruments.com



PICO
100 to 10,000
VDC Outputs DC-DC CONVERTERS

4 Watt to 10 Watt Series
Surface Mount & Plug In
Over 250 Standard Models!
Isolated Outputs/
Proportional V in and V out
Miniature fully encapsulated modules for
operation in rugged environment

Military options available

Expanded operating temperature
-55° to +85° C Ambient

Military Standard 883 Selected
testing available

Will review all Customer Specifications
for custom design specifications

Over 2,500 standard high and
low voltage DC-DC converters and
AC-DC power supplies

Industrial/Cots/Military
Isolated/Regulated/Proportional/
Programmable

Also Thousands of Hi reliability,
Ultra Miniature Transformers
and Inductors

US Manufactured
since 1969



See PICO's full line catalog at
www.picoelectronics.com

PICO ELECTRONICS, Inc.

Pico Representatives

Germany
ELBV/Electronicse Bauelemente Vertrieb
E-mail: info@elbv.de
Phone: 0049 89 4602852
Fax: 0049 89 46205442

England
Ginsbury Electronics Ltd.
E-mail: rbennett@ginsbury.co.uk
Phone: 0044 1634 298900
Fax: 0044 1634 290904



Haptic drivers provide faster haptic response to enhance the end-user experience

Fairchild Semiconductor has developed a haptic driver to help designers overcome the challenges posed by slow response times and large battery drains to enhance the end-user experience through excellent recognition and a user-friendly interface. The FAH4830 haptic driver provides a touch sensation when a user interacts with a touch screen. The sensory interaction between the user and mobile device - such as tablets, PCs, medical devices, video games systems and smart phones - creates a more local effect and assures the user of a correct 'point-of-touch' on the screen. Offering direct driving capability of eccentric rotating mass (ERM) motors and linear resonant actuators (LRA), the FAH4830 driver enables a vibrating sensation on point-of-contact. The typical driver wake-up time of the device is <math><30\ \mu\text{s}</math> which helps to reduce latency and provides a fast haptic response.

Fairchild Semiconductor
www.fairchildsemi.com

Dynamic NFC-screen overlays multiple NFC tags within the displayed content

NFC start-up Think&Go NFC has launched a patented Dynamic NFC-screen that allows consumers to communicate "through" a video display using their NFC smartphones.



Consumers can pick up product information, collect coupons and navigate through advertising and presentation media just by placing their NFC phone close the display surface.

The screen features a grid of embedded NFC tags connected to the screen controller, or the application's processor, enabling the tags to change the display content based on user interaction or the information fetched from NFC phones. Any of the multiple embedded NFC tags can be highlighted on the video display and the NFC content and video content change dynamically and synchronously. The Dynamic NFC can also read the identity of the NFC phone allowing total personalization of content for this individual user who chooses to opt-in. A very basic use would display a sequence of videos presenting fashion items with target marks allowing consumers to access more information or an m-commerce site to buy the product. The perfect local synchronization between image and multiple NFC function makes campaigns easy to build, but also opens a path to totally new interactive scenarios: Coupons can be hidden in interactive games or questionnaires; Coupons can become dynamic, changing value with time or according to the profile of the individual consumer; Consumers can navigate through a product catalogue and directly order products that are presented with instant access high quality video. The company makes available a Dynamic NFC-Screen SDK that uses a simple script programming language to build exciting interactive campaigns.

Think&Go
www.thinkandgo-nfc.com

Win a kit to evaluate Atmel's complete 2.4GHz system-on-chip solution

This month, Atmel is giving away three ATmega256RFR2 evaluation kits, worth \$349 each, for EETimes Europe's readers to win. The kit demonstrates the unique performance of the latest Atmel 2.4GHz System-on-chip solution, ATmega256RFR2, offering a hardware platform for evaluating complete wireless system solutions including wireless stacks such as IPv6/6LoWPAN, ZigBee RF4CE and ZigBee PRO. The kit can also be used to evaluate and develop various proprietary systems using low level drivers or the new Atmel Lightweight Mesh Stack. Included in the kit are two radio controller boards (RCB) assembled with the ATmega256RFR2, powered by two AAA batteries and forming a fully functional and portable wireless node. The kit also includes a sensor terminal board (STB) for connection to a PC/laptop, and one Key Remote Control Board enabling demo/evaluation of remote control applications like ZigBee Remote Control and ZigBee Light Link. An RS232 cable, a USB cable and two 2.4GHz antenna complete the package.



Check the reader offer online at
www.electronics-eetimes.com

IR time-of-flight proximity sensor opens up new smartphone user interactions

Combining three optical elements in a single compact package, the VL6180 is the first member of ST's FlightSense family and uses a new optical-sensing technology that enables innovative new user interactions with smartphones. The VL6180 uses a proximity measuring technology to offer unprecedented accuracy and reliability in calculating the distance between the smartphone and the user. Instead of estimating distance by measuring the amount of light reflected back from the object, which is significantly influenced by colour and surface, the sensor precisely measures the time the light takes to travel to the nearest object and reflect back to the sensor. This "Time-of-Flight" approach ignores the amount of light reflected back and only considers the time for the light to make the return journey. The key to ST's patented new solution is an infra-red emitter that sends out light pulses, an ultra-fast light detector that picks up the reflected pulses, and electronic circuitry that accurately measures the time difference between the emission of a pulse and the detection of its reflection. The VL6180 embeds both a robust ranging time-of-flight sensor and a wide dynamic ambient light sensor die, along with an infra-red emitter.



STMicroelectronics
www.st.com

Plug-retention safeguard for IEC appliance inlets and cord sets

Schurter is continually expanding its standard line of power-inlet connectors and cord sets for the V-Lock system. More than 50 appliance power-inlet connectors and power entry



modules as well as more than 40 power cables with various plugs, lengths and current ratings are available from stock. For applications in medical technology, power cables in white and in "American Hospital Grade" are also available. V-Lock guarantees that a power cable cannot be inadvertently pulled

out of an appliance. With this system, the cord connector is equipped with a pin that interlocks with a special notch in the appliance inlet. The press of a finger on the release lever then frees the interlock. V-Lock is easily recognized due to its bright yellow colour, a feature that makes it easy to identify this scheme and clearly distinguishes it from conventional power inlet-plug/socket systems. The V-Lock locking system can be integrated into appliance couplers in compliance with IEC 60320 for rated currents of 10 A and 16 A. A key advantage is that there is no need to attach and adapt a clamping system or retaining bracket specific to a unit's power socket. Plug retention is extremely useful everywhere there is the possibility that power could be unintentionally interrupted, whether caused by a unit's mobile design, vibrations, the unit being moved or improper use by operating personnel.

Schurter

<http://v-lock.schurter.com>

Ultra fast camera lens enables full-resolution touch and re-focus mobile applications

A manufacturer of high-speed and ultra-low power autofocus actuated lenses, poLight has developed a new type of applications for its TLens (tunable lens) actuator, that enables users



to refocus a picture once it has been taken. TLens boosts smart phone camera performance thanks to a response time 20x faster than traditional VCM technologies, while consuming 40x less power consumption to prevent the sensor from heating and

to extend battery life in continuous autofocus mode. Those performance discontinuities enable new mobile applications such as video continuous autofocus, instant focus or all-in-focus. The new Touch & re-Focus software enables users to refocus a picture once it has been taken. By simply touching the area where to focus on the smart phone screen, the new generated picture can then be saved at full sensor resolution while image files are sent to the cloud to generate other focusing scenarios at a later time. Alternatively, the photographer may decide to get there image "all-in-focus" by using a simple slider from the application screen. Hence close-up and far away objects on the scene are all in focus. With a TLens-based camera, users will be able to shoot their pictures without the risk of missing a focus, claims the company. The "Touch & re-Focus" feature then lets them adapt later the focus of their full-resolution picture directly on their phone or on their PC.

TLens

www.polight.com

LED in flip-chip die offers more flexibility for luminaire designers

Philips Lumileds has introduced LUXEON flip chip LED devices which are said to enable the next generation of lighting applications: The robust flip chip die format gives luminaire greater design options than in the past. With the availability of LEDs implemented in flip chip technology, luminaire manufacturers have the choice between conventional wire bonding and the flip chip technology and thus they can enjoy the best of both worlds, said Philips Lumileds CEO Pierre-Yves Lesaichere. "They can either incorporate packaged LEDs as they did in the past, or start with the LED die and customize the phosphor and packaging to best suit their lighting application", he said. While traditional wire bonding limits the packing and power density of LEDs, LUXEON Flip Chip LEDs can be packaged closer and can be driven at a higher current density. This requires fewer emitters to achieve a higher lumen output at higher lumen densities, a capability that is especially advantageous with chip-on-board and other high-power applications. The usage of flip chip devices translates into higher lumens per dollar through higher lumen densities and a straightforward packaging process, Lesaichere said. Philips Lumileds introduced high-power LUXEON Flip Chips in a 1.0x1.0mm format at the Strategies in Light trade fair in San Jose, California. These chips take advantage of the same epitaxial technology, materials and design as do other LUXEON LEDs, the company said.

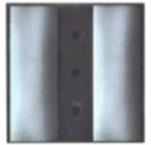

Philips Lumileds

www.philipslumileds.com

System-in-package with no-tune antenna simplifies and speeds NFC integration

The all-in-one ComboPulse from Inside Secure is a secure near field communication (NFC) system-in-package (SiP). This is a drop-in, zero-tuning solution that makes it easy and inexpensive to add NFC

functionality into a broad range of mainstream consumer electronic products, including tablets, entry-level mobile phones, personal media players and other smart mobile devices. Combining

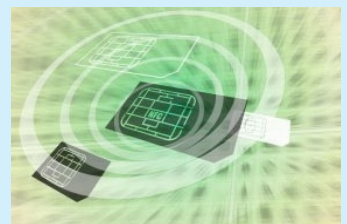

the company's PicoPulse™ NFC RF front end "booster" chip, the company's VaultSEcure(TM) secure element with Java Card OS, an antenna and all passive components in a tiny DFN8 package, the ComboPulse SiP requires no additional hardware, no external antenna and no tuning to add best-in-class NFC card emulation and peer-to-peer functions to mobile products at a fraction of the cost and time of traditional NFC solutions. The NFC card emulation capability provided by the ComboPulse SiP allows the mobile device to be used like a contactless smart card to communicate with standard contactless POS and other terminals. Peer-to-peer (P2P) mode operation provided by the ComboPulse device can simplify Bluetooth and Wi-Fi pairing between two consumer electronic devices. P2P can be used to easily exchange content or information with any NFC Forum compliant device.

Inside Secure

www.insidesecond.com

3D shape representation technology reduces memory load in machine tools

Mitsubishi Electric has developed ultra-high resolution 3D shape representation technology with resolution down to 1 micron for numerically controlled (NC) machine tools. The technology displays detailed shapes of machined surfaces down to a resolution of 1µm in a 3D machining simulation, which machine operators can use to evaluate surface textures without trial cutting through a high quality machining process and allows checks for possible over- or under-processing marks or scratches. Cutting devices are controlled by CAD machining programs and computer-aided manufacturing (CAM) programs. High-definition 3D simulated finishing leads to more efficient production by permitting operators to evaluate surface texture outcomes, as well as by eliminating the need for tests of actual high-grade machining. Complex shapes are displayed with limited data using Mitsubishi's unique Multi-ADF (adaptive distance field) shape-representation technology and Mitsubishi has improved the run time by reducing the data storage requirement to 50MB, two orders of magnitude less than conventional high-resolution 3D simulations. The 3D representation of multi-ADF proprietary technology uses less than 1% of the storage capacity required by conventional, high-resolution geometric model resolutions at the 1 micron level. Multi-ADF represents 3D shapes with a set of tiny cubes each with refined descriptions of multiple surfaces on them. This technology makes it possible to display dents and scratches on machined surfaces down to a resolution of one micrometer using fewer cubes, allowing high-speed simulations that require little memory.

Mitsubishi Electric
www.MitsubishiElectric.com

7-way multi-pin waterproof connector rated for use in the -55 to +125°C temperature range

Intelliconnect has introduced a new 7-way multi-pin waterproof connector featuring push-pull design for ease of connection and disconnection, suitable for harsh environments. The multi-pin



connector is waterproof to 10m in the unmated condition (both halves), has an operating temperature range of -55 to +125°C and the socket is connected directly into the PCB via solderable printed circuit tails.

The push-pull connection design provides maximum ease of connection and disconnection and has a keyway for alignment and secure orientation and has an operating life of greater than 500 cycles. The socket may be mounted on panels of thickness 5.5 to 8.0mm. The new Pisces connector meets MIL-PRF-39012, MIL-STD-348 and is RoHS compliant and is designed and manufactured in the UK with 100% locally sourced components. Custom designed versions of the new 7 way multi-pin are available via Intelliconnect's fast turnaround custom design service with drawings available in 24 hours and prototype parts available in 7 weeks.

Intelliconnect (Europe)
www.intelliconnect.co.uk

PC oscilloscopes with USB 3.0 interface enable captures and streaming of large data sets

The PicoScope 3207A is a 2 channel USB oscilloscope with 250 MHz bandwidth, 1 GS/s sampling rate, 256 MS buffer memory and a built-in function generator. Basic timebase accuracy is ±2 ppm. Other features include digital triggering for accurate, stable waveform display, and equivalent-time sampling, which boosts the effective sampling rate to 10 GS/s for repetitive signals. The PicoScope 3207B has 512 MS buffer memory and an additional 32k-sample arbitrary waveform generator with 100 MS/s update rate. As the scope obtains its power from the USB port, there is no need for an external power adaptor. With these new USB 3.0 PicoScopes, large data captures and streaming of large data sets will be much faster. The oscilloscopes are supplied with the PicoScope software for Windows, which turns your computer into a powerful oscilloscope and spectrum analyzer. The software includes many advanced features such as automatic measurements, serial decoding of RS-232/UART, SPI, I2C, CAN, LIN and FlexRay data, and mask limit testing, that are only available as expensive add-ons for most competing scopes. Software updates are free of charge. A free software development kit (SDK) is also available for those who wish to write their own data-acquisition programs. Example code in a number of languages is included.



Pico Technology
www.picotech.com

XMOS takes four core microcontroller below \$3

XMOS has launched a four core Microcontroller for under \$3 to open up multicore designs to low quantity and distribution customers. The xCORE XS1-L4-64 integrates four 32bit logical processor cores with 64KB of SRAM at a price that is comparable with competing single-core devices. Priced at just \$2.95 in 100-unit quantities through global distributors, the L4 provides an entry-level platform for designers considering multicore technology for the first time. It is pin-compatible with other members of the xCORE family, opening up the opportunity to cost reduce existing designs. The new device is aimed at accurate stepper motor control, industrial networking and motion control. With 64bit precision DSP capability, it is also particularly well suited for signal conditioning tasks and applications such as control that combine cost-sensitivity with high performance demands. The xCORE L4 will also help drive the growing trend towards distributed intelligence in embedded design, by allowing developers to locate low-cost processing and communications closer to system nodes such as sensors and actuators. "The L4 breaks new ground by combining low unit cost, real-time deterministic execution, multicore performance, on-chip DSP and the industry's fastest response times," said Nigel Toon, President and CEO, XMOS. The XS1-L4-64 comes in a 48-pin package that is pin-compatible with the existing 6-core L6-64 and the 8-core L8-64 xCORE devices.



XMOS
www.xmos.com

Mouser opens enhanced harsh environments site

Mouser Electronics has released a newly enhanced version of its Harsh Environment Technology site, with the addition of a special section devoted to Vibration Isolation Technology. The site includes educational resources on topics including Ingress Protection (IP) Ratings, NEMA Ratings, extended temperature range tolerance and the newly added Vibration Isolation spotlight. These criteria are paramount when designing equipment for rugged environments and applications. The Harsh Environment Technology site enables design engineers to select high-reliability parts which have been tested and proven to perform at extreme standards, often surpassing military specifications. The new Vibration Isolation section spotlights the challenges posed by shock and impact caused by vibration and the importance of identifying products optimized for vibration isolation and resilience.

Mouser Electronics
www.mouser.com

Rutronik distributes Toshiba's first 19nm NAND SSDs

Toshiba now delivers the world's smallest and highest density NAND flash solid state drive, using its advanced MLC (Multi-Level Cell) 19nm NAND technology. The THNSNF series comes with a high capacity of up to 512 GB. The SSDs are available at distributor Rutronik as of now. Toshiba's new series of SSDs will help OEMs balance the increasing demand for high storage capacity with the demand for more streamlined devices.



The THNSNF family offers a read transfer rate of 524MB/s and a write transfer rate of up to 461MB/s. It features Toshiba's Quadruple Swing-By Code, a strong and highly efficient Error Correction Code (ECC) protecting against any read errors in the device. An additional 'data corrupt protection' feature protects any data which is being moved internally, against unexpected power-loss and write errors.

Rutronik
www.rutronik.com

RS Components supports rapid prototyping with mbed application board

RS Components now stocks a new mbed application board that includes a host of connectors and external interfaces, eliminating the requirement for add-on boards and thus reducing valuable design time for engineers. The credit-card sized (54x86mm) application board is specifically designed for use with the mbed NXP LPC1768 Microcontroller module. The mbed application board includes a 128x32 graphics LCD; a 3-axis accelerometer; temperature sensor; servo-motor headers; PWM controlled LEDs; socket for ZigBee, Wi-Fi and Bluetooth wireless connectivity; Ethernet and USB connectors; and a speaker and I/O audio jacks.



RS Components
www.rs-components.com

Nordic Semiconductor adds Distrelec ELFA Group to its European distribution network

Nordic Semiconductor ASA has added specialist low volume, rapid delivery Swiss catalog distributor Distrelec to Nordic's European distribution network. Distrelec ELFA Group specializes in stocking a wide range of parts across three main European warehouse hubs in Switzerland, Sweden, and Germany, that are typically shipped overnight to pre-production design and prototyping customers in 29 countries, as well as students, academic researchers, and hobbyists. The distributor also has 40 full-time technical support engineers in Europe with two specializing exclusively in wireless technology. "Wireless is a rapidly expanding business for us," said Jürg Hübscher, Head of Distribution & Project Management at Distrelec. "And in particular the ultra low power segment is booming, particularly with the advent of Bluetooth low energy, because of the way it has opened up access to the smartphone and app markets."

Nordic Semiconductor
www.nordicsemi.com

Transonics signs for relay distribution with Hongfa

Transonics have signed a franchise agreement with Hongfa one of the largest relay manufacturers in the world with an annual production capacity of 1 billion pieces. Hongfa has 20 manufacturing subsidiaries, boasting a total factory area of some 330,000m² and designs and manufactures its own advanced automated manufacturing systems for relay production. The new agreement allows Transonics access to the complete range of relays manufactured by Hongfa which includes 160 different series of relay types, with some 40,000 different models, all of which are accredited by UL/CUL, VDE, TÜV, and CQC.



Transonics
www.transonics.com

Cree and Acal BFI sign GaN RF franchise agreement

Cree and Acal BFI have signed a franchise agreement, to increase the sale of Cree RF components in Italy, Spain, Germany, Poland, Czech Republic, The Netherlands, Norway, Sweden, Hungary and Luxemburg. "GaN is increasingly recognised as a key technology in bringing about improved efficiency and reducing overall systems costs, Cree and Acal BFI have joined forces to accelerate bringing this advantage to a wider market" said Tom Dekker, World Sales and Marketing Director for RF Technology at Cree. "A partnership with the leading innovator in the key area of GaN RF allows Acal BFI to increase its offer of advanced solutions at the very forefront of technology." said Lee Austin, Business Development Director Acal BFI communications division.

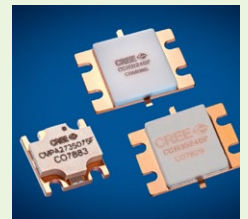

Acal BFI
www.acalbfi.com

PUBLISHER

André Rousselot
+32 27400053
andre.rousselot@eetimes.be

EDITOR-IN-CHIEF

Julien Happich
+33 153907865
julien.happich@eetimes.be

EDITORS

Nick Flaherty
+44 7710236368
nick.flaherty@eetimes.be
Christoph Hammerschmidt
+49 8944450209
chammerschmidt@gmx.net

CONTRIBUTING EDITORS

Paul Buckley
+44 1962866460
paul@activewords.co.uk
Jean-Pierre Joosting
+44 7800548133
jean-pierre.joosting@eetimes.be

CIRCULATION & FINANCE

Luc Desimpel
luc.desimpel@eetimes.be

ADVERTISING PRODUCTION & REPRINTS

Lydia Gijsegom
lydia.gijsegom@eetimes.be

ART MANAGER

Jean-Paul Speliers

ACCOUNTING

Ricardo Pinto Ferreira

REGIONAL ADVERTISING REPRESENTATIVES

Contact information at:
<http://www.electronics-eetimes.com/en/about/sales-contacts.html>



EUROPEAN BUSINESS PRESS SA

7 Avenue Reine Astrid
1310 La Hulpe
Tel: +32 (0)2 740 00 50
Fax: +32 (0)2 740 00 59
www.electronics-eetimes.com
VAT Registration: BE 461.357.437
RPM: Brussels
Company Number: 0461357437

© 2013 E.B.P. SA

ELECTRONIC ENGINEERING TIMES EUROPE is published 11 times in 2013 by European Business Press SA, 7 Avenue Reine Astrid, 1310 La Hulpe, Belgium
Tel: +32-2-740 00 50 Fax: +32-2-740 00 59
email: info@eetimes.be VAT Registration: BE 461.357.437
RPM: Nivelles. Volume 15, Issue 3 EE Times P 304128
It is free to qualified engineers and managers involved in engineering decisions – see:
<http://www.electronics-eetimes.com/subscribe>
Copyright 2013 by European Business Press SA.
All rights reserved. P 304128

LAST WORD

Raising the standard

By Kevin Price

THE ECONOMIC DRIVERS for cutting energy waste are indisputable. Energy represents the single largest operating and maintenance expense for manufacturers, forming 60%, excluding labour, of a typical Operations and Maintenance (O&M) budget. And alarmingly, research shows that up to 80% of this energy is wasted. To convert that into hard cash, for the worst performing manufacturers, that could mean that for every £100 in their non-labour O&M budget, £48 is effectively heading down the drain. With electricity prices up 30% since 2003; and predicted to rise by another 27% by 2020, failure to accept and address this relationship between energy waste and profitability has colossal implications.

The good news is that traditional asset management programmes now incorporate sustainability and energy efficiency, driving action to tackle this wasted energy and associated profit. Best practice asset sustainability works through capturing and processing the millions of dynamic pieces of data necessary to assess how efficiently an asset (ie piece of equipment, system, structure, facility, or enterprise) is operating on a continuous 24/7 basis.

Applied fully, it highlights the actual energy being consumed in the course of operation or production, and the facilities, systems, components, or processes which are consuming disproportionately more energy than they should.

Through identifying those facilities that spend more per square foot per year than expected, or more per product produced than expected, by monitoring and measuring energy intensity (usage, quality, consumption and efficiency), a holistic view of energy performance can be derived. Yet for many, the savings achievable from such an approach are being hindered by a lack of policy and/or buy-in from senior management.

Kevin Price is senior product manager, Enterprise Asset Management at Infor – www.infor.com

In many cases, energy management exists in silos, managed by different individuals or departments. However if communication between those charged with initiatives is lacking, the inherent relationship between energy responsibility (paying the costs) and accountability (knowing what drives the cost) may not be recognised or capitalised on. Securing buy-in from senior management is crucial in developing and implementing an organisation's energy management strategy. Through engaging the board, accountability and responsibility are put in place to ensure a strategy is cohesive and orientated towards overall organisational goals. Supported by an energy policy, which is integral in aligning an organisation's energy management practices, programmes and processes can then be measured effectively. But until recently, there has been a distinct lack of guidance



“Until recently, there has been a distinct lack of guidance and best practice on how best to establish realistic energy policies”

and best practice on how best to establish realistic energy policies, identify, implement and monitor energy reduction programmes, and systematically address energy waste in day-to-day operations.

However ISO 50001, a standard which sets out guidelines for a systematic and reliable way to investigate the relationship between energy usage and managing assets, from policy to the plug, is set to bridge this void. ISO 50001 specifies requirements for “establishing, implementing, maintaining and improving an energy management system, whose purpose is to enable

an organisation to follow a systematic approach in achieving continual improvement of energy performance, including energy efficiency, energy use, and consumption.” It also addresses energy cost issues as a way to demonstrate both the financial and environmental benefits which can be realised through systematic energy management.

Providing a framework for action and for the setting of energy objectives and energy targets, the standard helps to define organisational alignment with formal energy review mechanisms.

EET Search

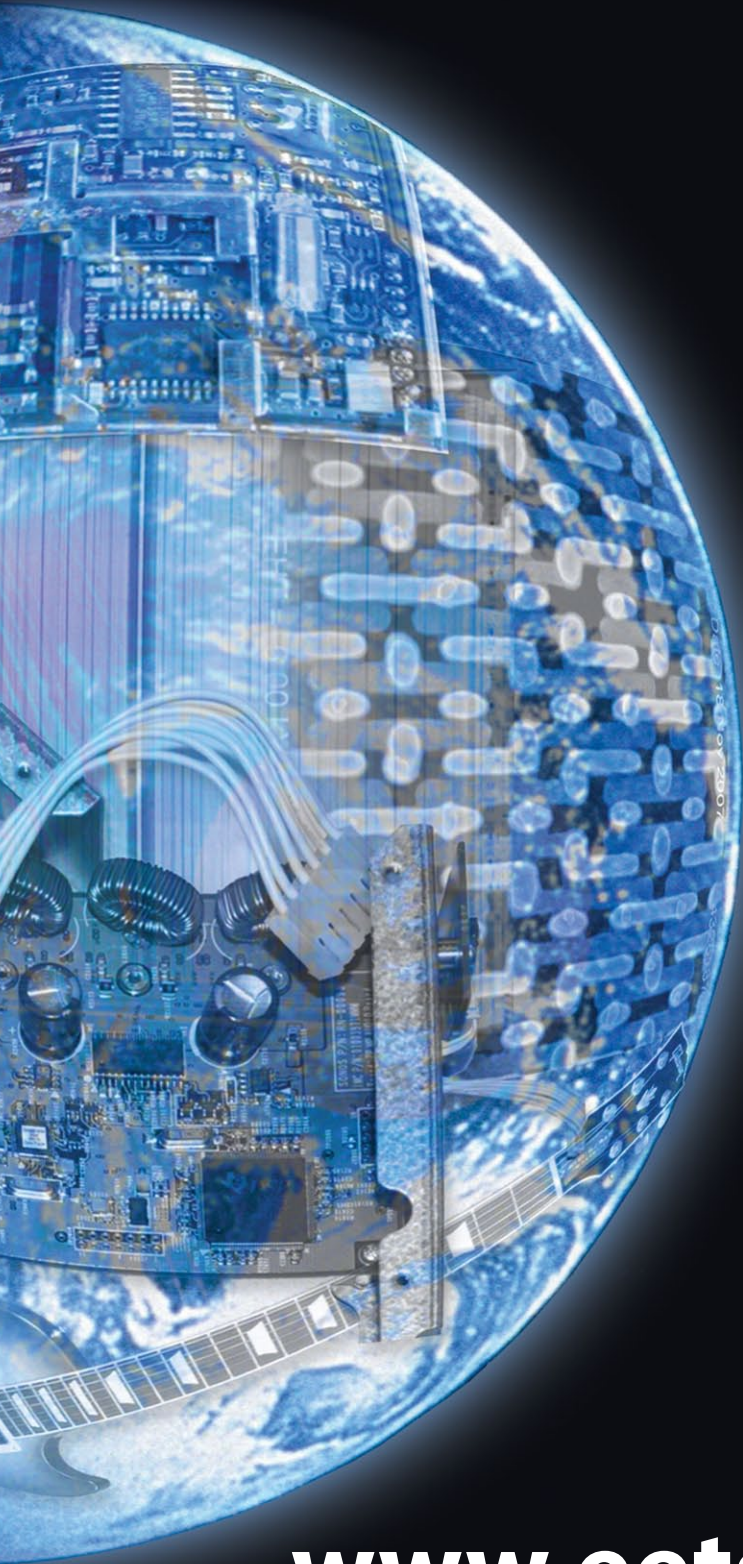

- searches all electronics sites**
- displays only electronics results**
- is available on your mobile**

www.eetsearch.com

Crystal-free 8-bit USB PIC® microcontrollers cut system costs and power consumption

0.25% clock accuracy enables USB connectivity, eliminating the need for external crystal



Microchip's lowest-cost and smallest-form-factor USB microcontrollers (MCUs), feature pin counts of 14 to 100 pins and are the first 8-bit MCUs to integrate LCD control, battery-backed RTCC, and USB on a single chip.

Microchip's latest USB PIC® MCUs feature internal clock sources with 0.25% clock accuracy to enable USB connectivity with no external crystal. They are also the first USB MCUs to combine pin-counts ranging from 14 to 100, with high peripheral integration and up to 128 KB of Flash. The eXtreme Low Power (XLP) technology also keeps power consumption down to 35 μ A/MHz in active mode and 20 nA in sleep mode.

Lowest-cost and smallest-form-factor

The PIC16F145X MCUs give you USB connectivity and capacitive touch sensing, in addition to a wide range of integrated peripherals with footprints down to 4x4 mm.

High-performance touch-sensing with USB

With an integrated Charge Time Measurement Unit (CTMU) and 1.8 V to 5 V operation, PIC18F2X/4XK50 MCUs are pin-compatible with legacy PIC18 MCUs, giving an easy migration to higher-performance.

USB plus LCD control and a RTCC with Vbat

The PIC18F97J94 family gives you USB connectivity with LCD control, and a battery-backed real-time clock calendar (RTCC), all on a single 8-bit PIC® microcontroller.

GET STARTED IN 3 EASY STEPS:

1. Choose a peripheral mix and pin count to suit your application
2. Use the free USB stacks and software drivers for faster design
3. Start developing with low-cost development kits

For more information, go to: www.microchip.com/get/eu8bitUSB



Microcontrollers • Digital Signal Controllers • Analog • Memory • Wireless